













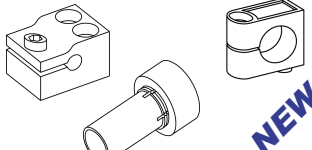

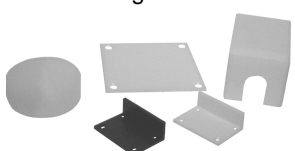

Sensor Brackets & Accessories 2004

S O F T N  Z E
USA, INC.

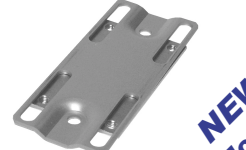
SENSOR ACCESSORY SOLUTIONS

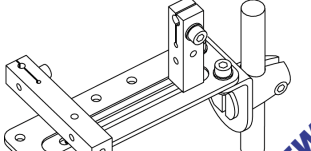
Product Selection Guide (If you do not see what you need....)





<p>Cushioned Sensor Mounts SN, SNB & SNM for tubular controls Pgs. 4 - 6</p>  <p>NEW Models</p>	<p>Quicktube™ & QuickMount™ QT & QM for tubular controls Pg. 7</p>  <p>NEW Models</p>	<p>QuickMount™ & Weld-on Block Mounts QM & BM-WO for tubular controls Pg. 8</p>  <p>NEW</p>	<p>Miniature Sensor Mounts MC, BM-PS, BM-MS-M, BM-M1, BM-MS, BM-MT & BM-M2 for miniature controls Pg. 8 & 9</p>  <p>NEW</p>
<p>Protective Caps & Faces EN, SC & CF for tubular controls Pg. 16</p> 	<p>Housing Covers, Shields & Material Deflectors HC, HS & MD for tubular & block style controls Pg. 17</p> 	<p>WeldJacket™ WJ for cordset & connector protection Pg. 18</p>  <p>NEW</p>	<p>FiberJacket™ FJ for fiber optic cable protection Pg. 19</p>  <p>NEW</p>
<p>ProxProbe™ Adapters PPA for shielded inductive sensors Pg. 24</p> 	<p>ProxPlunger™ & WeldSwitch™ PPL & WS for inductive sensors Pg. 25</p>  <p>NEW</p>	<p>Proxtrol Limit Switches PLS-M & PLS-1 prox-based limit switches Pgs. 26 - 28</p>  <p>NEW Models</p>	<p>Limit Switch Mounts LSM for limit switch-style controls Pg. 29</p>  <p>NEW Models</p>
<p>Reflectors & Brackets RB & PB for photoelectric sensors Pgs. 38 & 39</p>  <p>NEW</p>	<p>Fiber Optic Mounting FO for fiber optic sensors Pg. 39</p>  <p>NEW</p>	<p>SnakeMount™ SM for various sensor types Pg. 40</p>  <p>NEW</p>	<p>Sensor Wells SW for tubular controls Pgs. 41 & 42</p>  <p>NEW Models</p>

Welcome & Thank You! You now hold the most complete catalog of mounts and accessories for industrial sensors. When combined with our "CPR" process, you'll be freed from:

- Mounting and positioning frustrations
- Sensor replacement expenses
- Damaged reputations due to failed sensors
- Time consuming design & fabrication of your own brackets
- Idle equipment and production downtime
- Repeated calls to "readjust the sensors!"

In 1990 SoftNoze started with a single product the patented SoftNoze™ spring-loaded mount. Since this time, we have been working hard to create a comprehensive source for sensor accessories, so that you will have a single place to turn to for sensor and control mounting solutions. SoftNoze's only commitment is improving your sensor applications. After you have selected your sensors, please put us and our products to work for you. With our dedication and smart product design you will increase your sensor's usability and reliability. Best of all, you can start using your extra time to move on to more productive issues.

...please request SoftNoze CPR™, see pages 50 & 51 for details)

<p>Block Mounts & Block Mounting Systems BM & BMS for tubular/block-style controls Pgs. 10 & 11</p>  <p>NEW Models</p>	<p>Flat & Angle Brackets FB, FRAB, AB & RAB for tubular controls Pgs. 12 & 13</p>  <p>NEW Models</p>	<p>Introducing EMC Technology™ www.softnoze.com/emc Pg. 14 & 15</p> <div style="border: 1px solid black; padding: 10px; text-align: center;"> <p>Your Proximity Sensors + EMC Technology™ ----- Ultimate Sensor Applications</p> </div>	
<p>Conduit Adapters CA-R & CA-H for tubular controls Pg. 20</p> 	<p>Conversion Brackets CB for all sensor types Pg. 21</p> 	<p>ProxPort™ PP for tubular controls Pg. 21</p>  <p>NEW</p>	<p>Banking Screw Adapters BSA for shielded inductive sensors Pgs. 22 & 23</p>  <p>NEW Models</p>
<p>Clamp-style Universal Bracket CUB for all sensor types Pgs. 30 - 32</p>  <p>NEW Models</p>	<p>Sensor Mounting System SMS for all sensor types Pgs. 33 - 36</p>  <p>NEW Models</p>	<p>Clamp-style Universal & Universal Conveyor Brackets CUB & UCB for photo & ultrasonic sensors Pgs. 36 & 37</p>  <p>NEW Models</p>	<p>Articulating Universal Bracket AUB for block style sensors Pg. 38</p>  <p>NEW Models</p>
<p>SightGlass Mounts SG for tubular controls Pg. 43</p> 	<p>Test Set & ProxConverter™ TS1 & PC for electronic controls Pgs. 44 & 45</p>  <p>NEW</p>	<p>Custom Product Requests CPR Pgs. 46 & 47</p> <p>SoftNoze looks forward to and encourages all requests for new or modified products. Simply submit our CPR form and we'll do the rest!</p> 	

Call on SoftNoze, we are the mounting, positioning and protection experts for the following types of control devices:

- Inductive
- Capacitive
- Photoelectric
- Thermocouple
- Encoder
- Fiber-Optic
- Laser
- Ultrasonic
- Transducers/LVDT
- Electromechanical

SoftNoze Mission

To be the Industrial Control Industry's Preferred Supplier of Sensor Accessories.
Demonstrating Leadership in Quality, Service, Value and Technology.
Leading Technology For Industrial Sensor Integration

SoftNoze operates by procedures that follow guidelines in the ISO 9001:2000 standard.
Please feel free to request a copy of our Quality Manual.

Look!
New Styles for
4-6.5mm Proxes

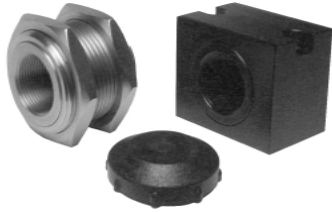

Spring-loaded sensor protection Install tubular proximity sensors with a Cushioned Sensor Mount to speedup installation, setup and protect against future accidental over-travel damage, replacement expense and downtime.



Patented

Features

- Spring-loaded housing mechanism
- Block style or threaded housing designs
- Shielded & non-shielded plastic caps
- Anodized aluminum or stainless steel

Benefits

- Ends downtime & replacement expenses
- Speeds sensor installation & setup times
- Eliminates abrasion & impact damage
- Reduces spare sensor inventories

In the past...

Sensors were fixed to machine frames leaving them vulnerable to impact and abrasion damage. During installation and setup, sensors had to be carefully positioned since small gaps between sensors and targets offered very little room for positioning errors. Often the practice was to keep sensors "backed-off" and "inch them closer" as equipment travel and control programs were verified.

However, this practice for establishing reliable sensor positions was extremely time consuming. Furthermore, normal equipment wear and tear would eventually close the sensing gap and lead to sensor damage and downtime.

In the past, small amounts of over-travel damaged sensors:

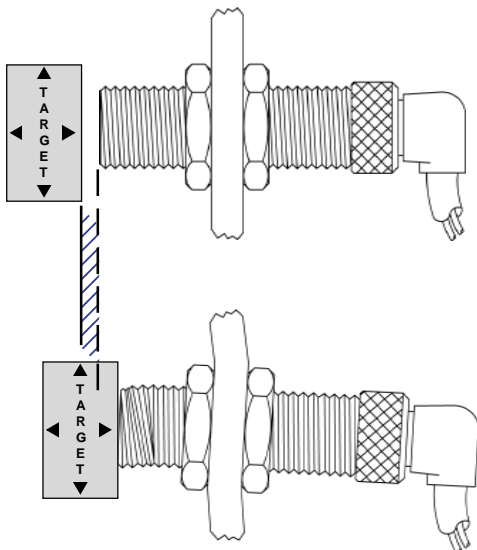

Today...

Your sensor installations, setup and performance can be greatly enhanced using Cushioned Sensor Mounts. Each mount contains a compression spring and holds the sensor securely. When targets over-travel the sensor simply retracts to avoid damage. More important, your equipment continues to operate.

A beveled plastic cap is included and accommodates side-traveling targets, while also eliminating abrasion damage. The Cushioned Sensor Mount equals faster equipment setup and eliminates future downtime.

Today, installing sensors with Cushioned Sensor Mounts increases allowable over-travel by 250 to 1000%!

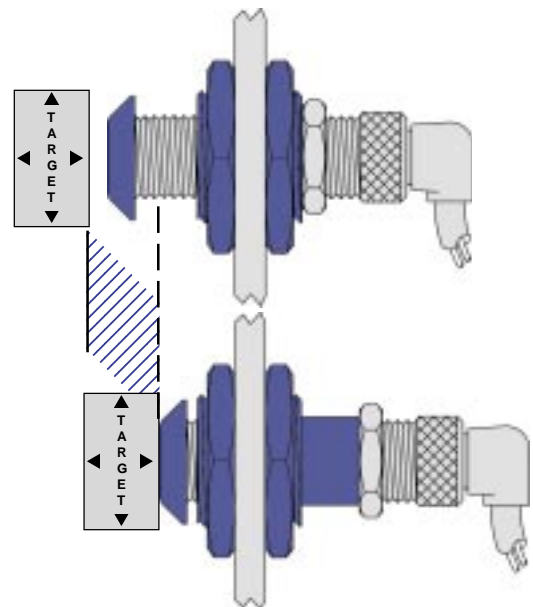

Cushioned Sensor Mounts

Micro-style SoftNoze Mounts Install small diameter proximity sensors with a spring-loaded cushion for overtravel protection and faster setup. Just as important our collet-style models will help eliminate housing damage commonly caused by using set screw mounting.

MicroCollet, Threaded Mount are attached via a threaded outside housing and lock nut. Sensor is secured with plastic collet nut and all other components are stainless steel:

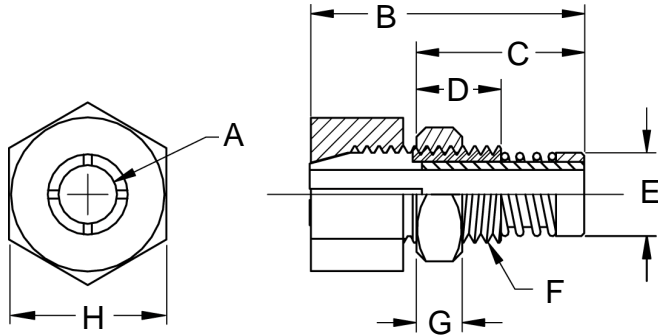

Model							
SNMC-T-04			SNMC-T-065				
A	4mm	E	6.91 (0.27)	A	6.5mm	E	10.9 (0.43)
B	26.2 (1.03)	F	M8x1	B	31.0 (1.22)	F	M12x1
C	15.2 (0.60)	G	4.00 (.160)	C	17.3 (0.68)	G	4.00 (0.16)
D	9.90 (0.39)	H	9.70 (.380)	D	9.90 (0.39)	H	12.7 (0.50)

MicroCollet, Flange Mount are attached via a flange-style housing with a M4 sockethead cap screw (SHCS). Sensor is secured with plastic collet nut and all other components are stainless steel:

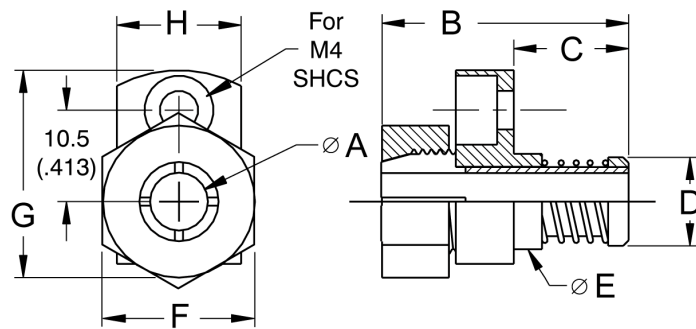

Model							
SNMC-F-04			SNMC-F-065				
A	4mm	E	7.90 (.310)	A	6.5mm	E	11.0 (0.43)
B	26.2 (1.03)	F	9.70 (0.38)	B	31.0 (1.22)	F	12.7 (0.50)
C	8.50 (.340)	G	21.3 (0.84)	C	10.7 (0.42)	G	22.4 (0.88)
D	6.90 (0.27)	H	11.2 (0.44)	D	10.9 (0.43)	H	14.2 (0.56)

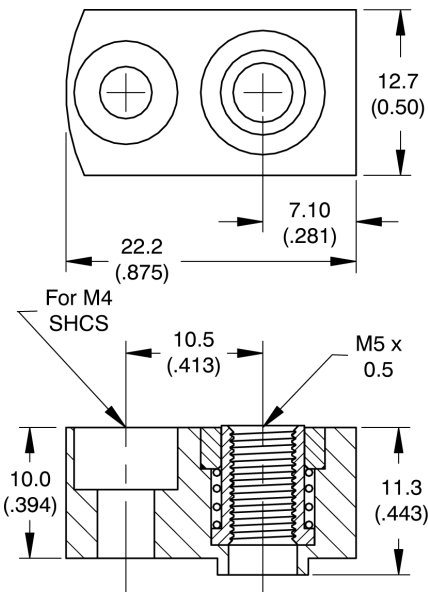

SNMTF-05

Mount is attached via a M4 sockethead cap screw (SHCS). Sensor threads into ID sleeve and is secured with a jam nut provided with sensor. All components are stainless steel.

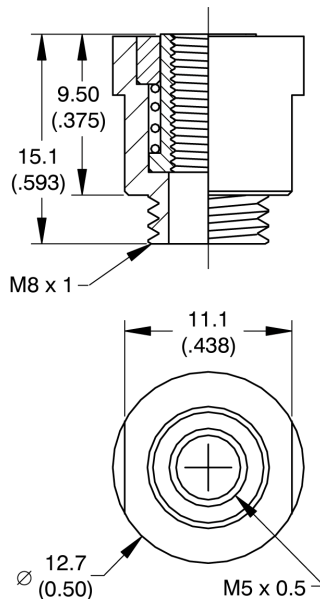

SNMTT-05

Mount attached via M8x1 threaded nipple. Sensor threads into the ID sleeve and is secured with a jam nut provided with sensor. All components are stainless steel.

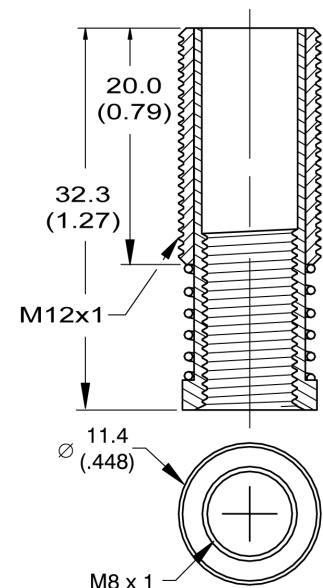

SN-08LP

Mount attached via M12x1 threaded nipple. Sensor threads into the ID sleeve and is secured with a jam nut provided with sensor. All components are stainless steel.

Cushioned Sensor Mounts

Models	A	B	C	D	E	F	G	H	I	J	O
SN-08	M8 x 1	M16 x 1.5	3.10 (0.12)	0.25 (0.01)	22.0 (0.87)	15.2 (0.60)	5.33 (0.21)	22.1 (0.87)	N/A		8.89 (0.35)
SN-08N									9.51 (0.37)	11.0 (0.43)	
SN-12-LP	M12 x 1	M18 x 1	4.06 (0.16)	0.51 (0.02)	24.0 (0.95)	22.9 (0.90)	6.35 (0.25)	21.1 (0.83)	N/A		12.1 (0.48)
SN-12N-LP									17.3 (0.68)	14.7 (0.58)	
SN-12		M22 x 1.5									
SN-12N								17.3 (0.68)	14.7 (0.58)		
SN-18	M18 x 1	M30 x 1.5	5.10 (0.20)	0.76 (0.03)	35.8 (1.41)	29.7 (1.17)	8.38 (0.33)	29.7 (1.17)	N/A		12.4 (0.49)
SN-18N									17.8 (0.70)	23.9 (0.94)	
SN-30	M30 x 1.5	M47 x 1.5									51.0 (1.72)
SN-30N										22.9 (0.90)	38.6 (1.52)

Specifications

The chart at left is for round, threaded models and the bottom chart for block-style models. In each case, model numbers with an "N" after the sensor thread size are for non-shielded sensors and correspond with figures on the right below each chart.

Caps are plastic and mount housings are anodized aluminum or stainless steel. For stainless steel mounts, add an "SS" to the end of the model number (accept model numbers SN-12-LP and SN-12N-LP, which are available only in stainless and do not require the "SS")

"O" in each table signifies the total allowable overtravel.

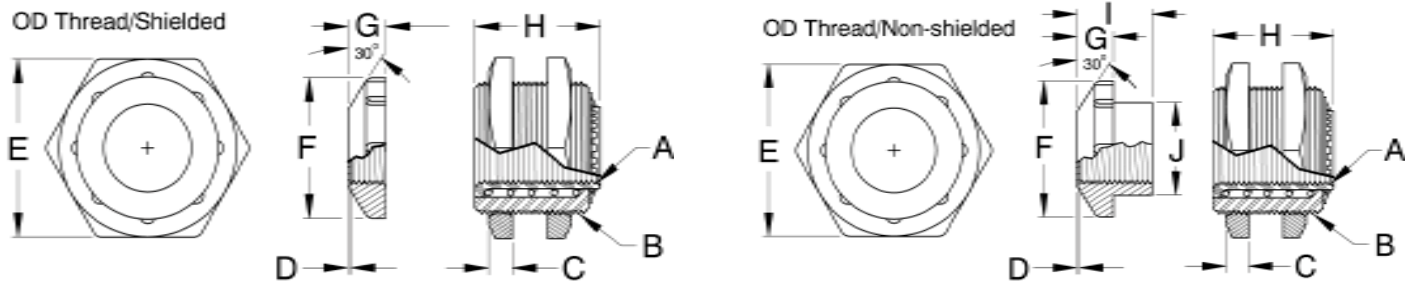

Models	A	B	C	D	E	F	G	H	I	J	K	L	M	O
SNB-08	M8 x 1	19.0 (0.75)	9.52 (0.37)	0.25 (0.01)	15.8 (0.62)	15.2 (0.60)	5.33 (0.21)	22.1 (0.87)	N/A		18.4 (0.72)	25.4 (1.00)	3.58 (0.14)	8.89 (0.35)
SNB-08N									9.51 (0.37)	11.0 (0.43)				
SNB-12	M12 x 1										0.51 (0.02)	25.4 (1.00)	22.9 (0.90)	6.35 (0.25)
SNB-12N								17.3 (0.68)	14.7 (0.58)					
SNB-18	M18 x 1	25.4 (1.00)	12.7 (0.50)	0.76 (0.03)	31.7 (1.25)	29.7 (1.17)	8.38 (0.33)	29.7 (1.17)	N/A		30.7 (1.21)	63.5 (2.50)	4.60 (0.18)	12.4 (0.49)
SNB-18N										17.8 (0.70)	23.9 (0.94)			
SN-30	M30 x 1.5	34.9 (1.38)	17.5 (0.68)			50.8 (2.00)	43.7 (1.72)	7.62 (0.30)	37.4 (1.47)	N/A			51.5 (2.03)	63.5 (2.50)
SN-30N									22.9 (0.90)	38.6 (1.52)				

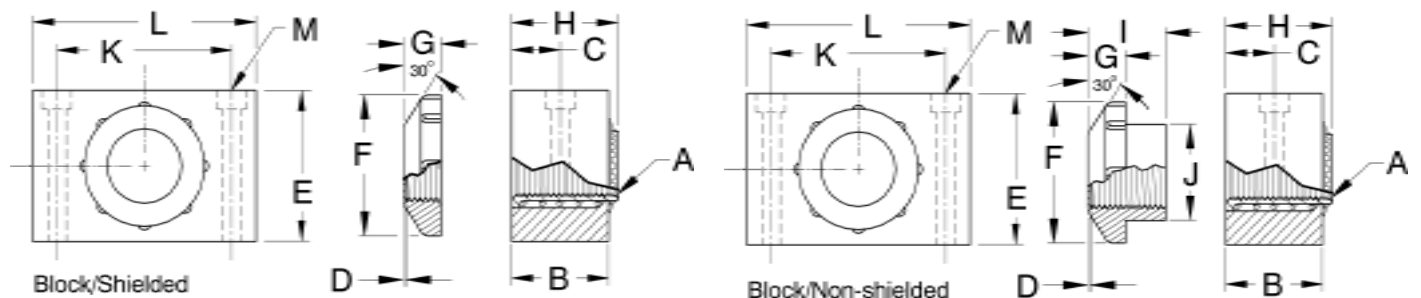



Quicktube™ Install tubular proximity sensors with a mount that securely holds and releases a sensor with a quick twist of a single collet-style nut. Speeds installation and replacement procedures.

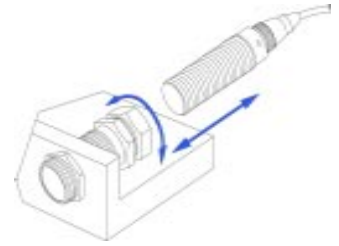

Features

- Collet-style locknut secures sensor
- Integral stop shoulder maintains target gap
- 8, 12, 18 and 30mm sizes
- Short or long barrel lengths

Benefits

- Housing protects sensor from physical impact
- Sensor change-out is fast, no adjustments required
- Target / product can rest on sensor face
- New applications for sensors



Use as a "Smart Rest Pad"

As shown at right, you can use Quicktube™ as a "smart rest pad" for tooling and fixturing. With sensors protected by Quicktube you can rest castings or work pieces right on your sensors. Quicktube can take the load and adjustments are easy via the threaded housing. Sensors confirm part positioning to initiate machining, welding or other control cycles.

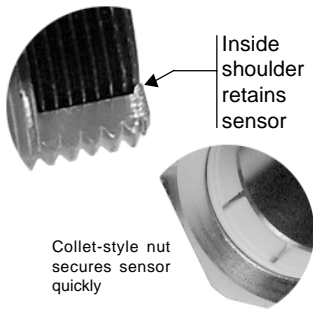
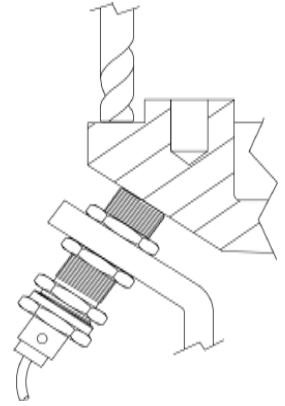

Unique features

The Quicktube™ has a small shoulder on the inside bore that retains the sensor at its sensing face. This feature prevents sensors from passing through and therefore the target gap is always maintained. Installation or removal takes only a few turns of the collet-style nut.

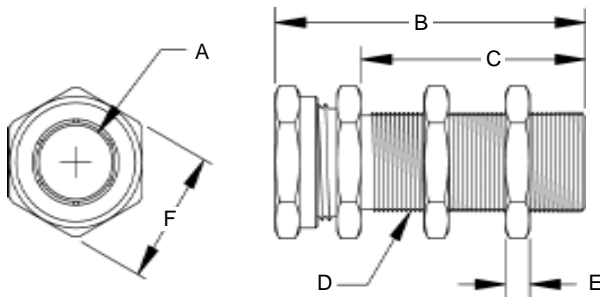

Model	A	B	C	D	E	A
QT-08	8.18 (0.32)	32.4 (1.28)	17.5 (0.69)	M12 x 1	3.85 (0.15)	16.9 (0.67)
QT-08L		48.0 (1.93)	34.0 (1.34)			
QT-12	12.1 (0.48)	33.7 (1.34)	19.5 (0.77)	M16 x 1	4.01 (0.16)	21.8 (0.86)
QT-12L		44.8 (1.76)	30.0 (1.18)			
QT-18	18.1 (0.71)	38.5 (1.52)	20.0 (0.79)	M24 x 1.5	4.95 (0.19)	30.0 (1.18)
QT-18L		58.0 (2.28)	40.0 (1.57)			
QT-30	30.1 (1.19)	35.0 (1.50)	20.0 (0.79)	M36 x 1.5	6.13 (0.24)	41.0 (1.61)
QT-30L		58.0 (2.28)	40.0 (1.57)			

Teflon® Coated

Teflon® coating repels weld splatter, select from model numbers below. All dimensions are equal to regular Quicktubes™.

Barrel	8mm	12mm	18mm	30mm
Short	QT-08-T	QT-12-T	QT-18-T	QT-30-T
Long	QT-08L-T	QT-12L-T	QT-18L-T	QT-30L-T

Plastic Housing

Identical dimensions to our regular "QT's" at left, but with a Delrin® polymer housings for when metal won't work! Mounting nuts are metal.

Barrel	8mm	12mm	18mm	30mm
Short	QT-08-P	QT-12-P	QT-18-P	QT-30-P
Long	QT-08L-P	QT-12L-P	QT-18L-P	QT-30L-P

Sealed Face Plastic Housing

A sealed face QT allows a water tight seal to be developed. Same dimensions as "long-style" QT's at left, accept for the wall thickness "A", as shown below:

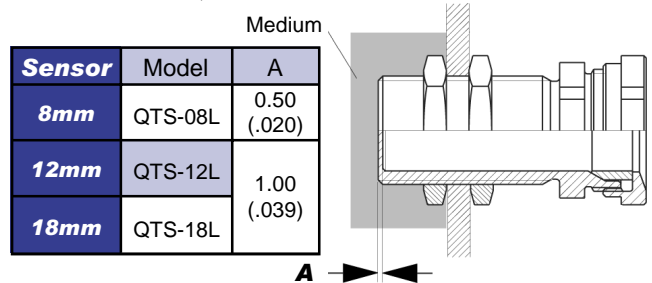

Sensor	Model	A
8mm	QTS-08L	0.50 (.020)
12mm	QTS-12L	1.00 (.039)
18mm	QTS-18L	

QuickMount™, Weld-On™ & MicroCollet™

QuickMount™ is a plastic block mount with a hinged lever top, which snaps closed to secure tubular sensors. Adjust via slotted mounting holes or by opening and closing hinged lever. Glass-filled Nylon for 12, 18 and 30mm sensors.

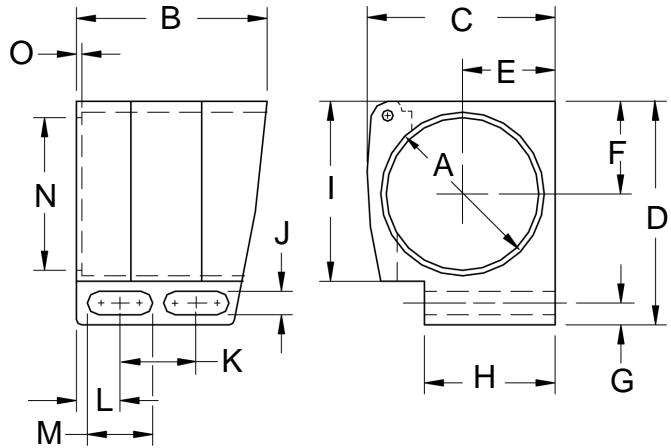

Model Number																	
BMQM-12					BMQM-18					BMQM-30							
A	12mm	F	8.00 (.315)	K	14.0 (.551)	A	18mm	F	11.5 (.453)	K	14.0 (.551)	A	30mm	F	17.1 (.673)	K	14.0 (.551)
B	30.0 (1.18)	G	4.00 (.157)	L	8.00 (.315)	B	30.0 (1.18)	G	4.00 (.157)	L	8.00 (.315)	B	35.1 (1.38)	G	4.00 (.157)	L	8.00 (.315)
C	18.0 (0.71)	H	8.00 (.315)	M	12.0 (.472)	C	24.0 (.945)	H	13.9 (.547)	M	12.0 (.472)	C	34.5 (1.36)	H	24.1 (.949)	M	12.0 (.472)
D	24.0 (0.95)	I	16.0 (0.63)	N	10.8 (.425)	D	29.0 (1.14)	I	21.0 (.827)	N	17.0 (.669)	D	41.1 (1.62)	I	33.3 (1.31)	N	28.1 (1.11)
E	8.00 (.315)	J	4.20 (.165)	O	0.25 (.001)	E	11.0 (.433)	J	4.20 (.165)	O	0.25 (.001)	E	17.5 (.689)	J	4.20 (.165)	O	0.25 (.001)

Weld-On™ unfinished steel HEX slugs, bored and tapped for 12, 18 and 30mm sensors. Ready to be welded into place to fully protect sensors from physical abuse. Threaded end has a built-in stop shoulder that insures sensor position.

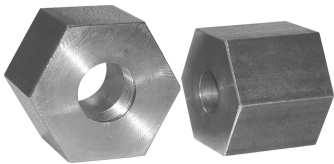

BM-WO-xx			
(suffix)	A	B	C*
-12	M12x1	33.3 (1.31)	30.2 (1.19)
-18	M18x1	6.91 (1.50)	
-30	M30x1.5	47.6 (1.88)	44.5 (1.75)

*Other lengths in stock, consult factory.

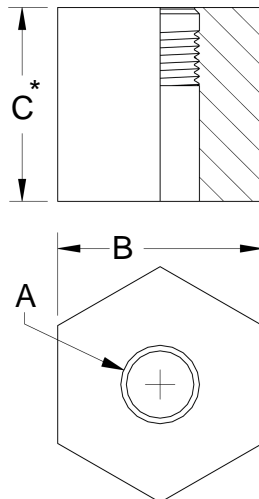

MicroCollet™ These collet-type sleeves allow for more secure and damage free mounting of 4 and 6.5mm sensors. Simply drill and ream your fixture and then bond the MicroCollet™ in place. Secure and adjust sensors with the Delrin® adjustment nut. Eliminates tapping and damaging set screws. Barrels are stainless steel.

Model	A	B	C	Ream fixture
MC-04	26.2 (1.03)	11.0 (.433)	9.70 (.380)	5.410 (.2130)
MC-6.5	31.0 (1.22)	13.7 (.539)	12.7 (0.50)	7.937 (.3125)

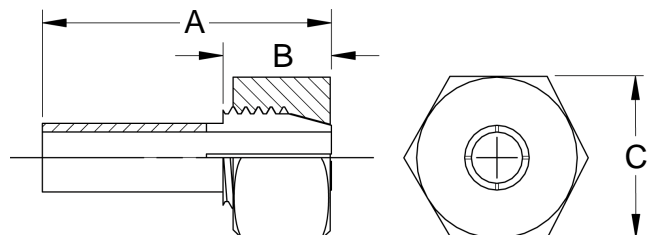

Miniature Sensor Mounts

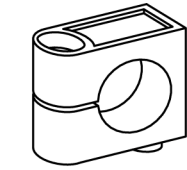
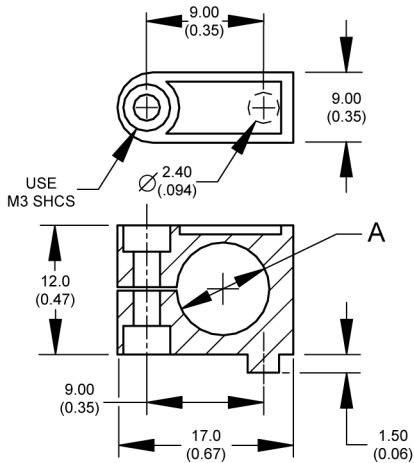

Block Mount Plastic Slotted

Model	A
BM-PS-04	4mm
BM-PS-05	5mm

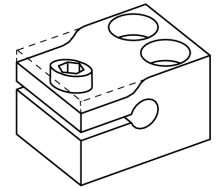
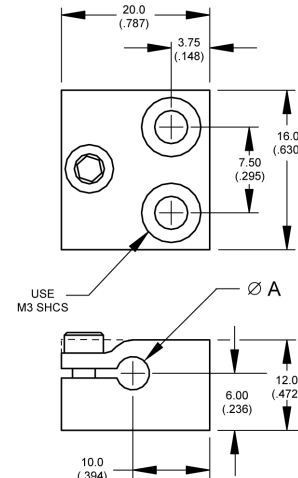

Block Mount Metal Slotted Micro

Model	A
BM-MSM-04	4mm
BM-MSM-6.5	6.5mm
BM-MSM-08	8mm

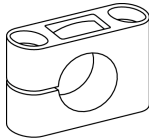
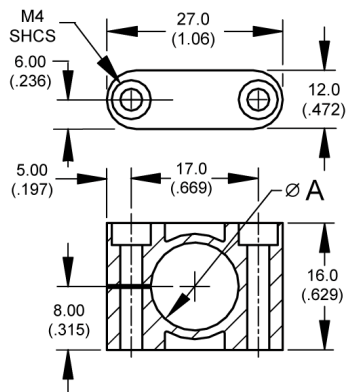

Block Mount Plastic Slotted Glass-filled Nylon

Model	A
BM-PS-6.5	6.5mm
BM-PS-08	8mm

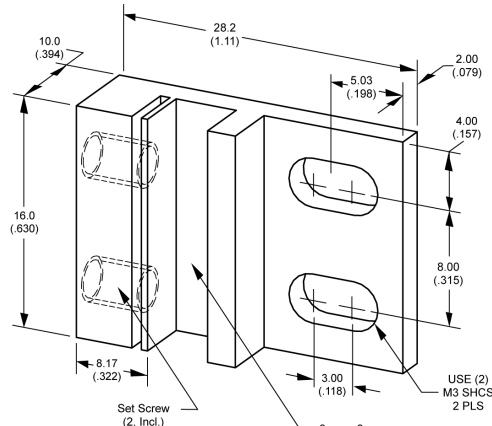

Block Mount Micro-type 1

Model
BM-M1-08
Notes
For 8mm x 8mm square body proximity sensors. Anodized Aluminum. Other models upon request.

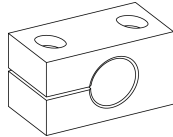
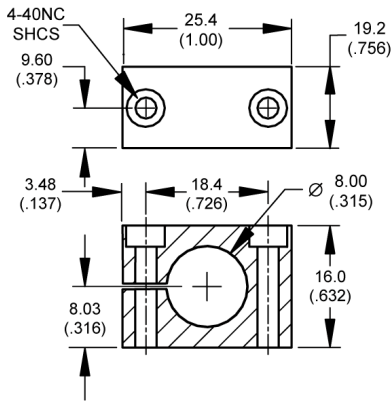

Block Mount Metal Slotted Anodized Aluminum

Model
BM-MS-08

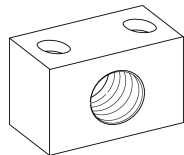
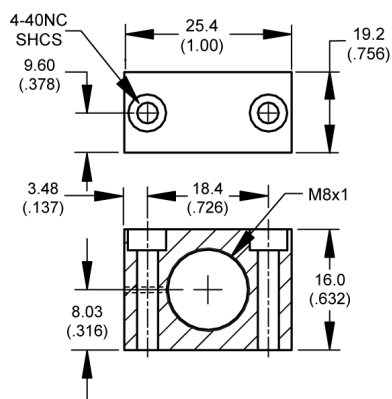

Block Mount Metal Threaded Anodized Aluminum

Model
BM-MT-08

BlockMount Micro-type2 Anodized Aluminum

Model
BM-M2-08
Notes
For 8mm x 8mm square body proximity sensors. Anodized Aluminum. Other models upon request.

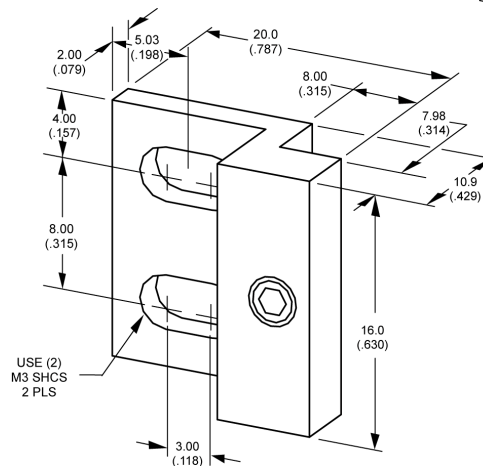
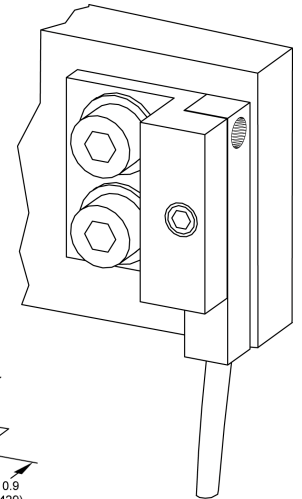

Block Mounts

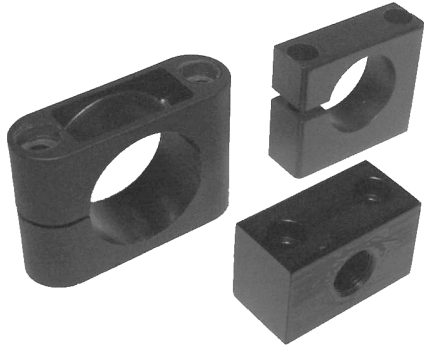

Block Style Mounts - For every application

Select from metal or plastic, threaded or slotted. Slotted types clamp-down to secure sensor via one of the mounting fasteners and allow easy adjustment. More rugged mounting is accomplished using a metal, threaded, mount.

Features

- Four different styles
- Sizes for most tubular sensor diameters
- Anodized aluminum or glass-filled nylon

Benefits

- Off-the-shelf mounting solution
- Secure attachment methods
- Easy installation

Plastic Slotted

PS type

Glass-filled Nylon

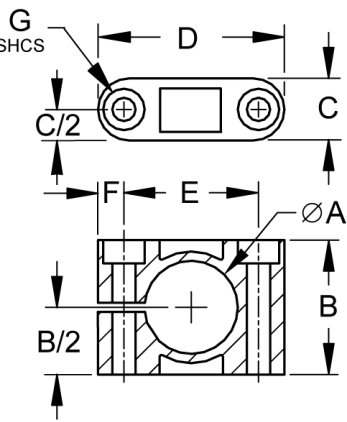
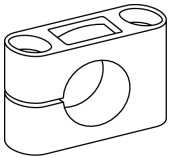

Plastic Threaded

PT type

Delrin®, stainless steel mounting hardware included

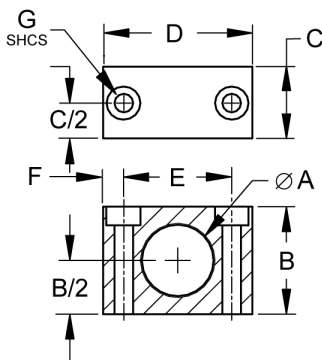

Metal Threaded

MT type

Anodized aluminum

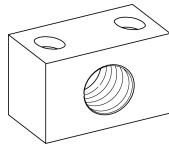

Metal Slotted

MS type

Anodized aluminum

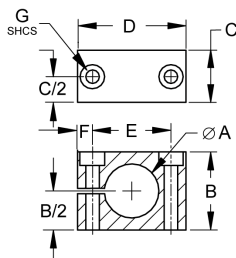
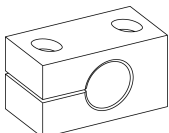

Model	A	B	C	D	E	F	G
BM-PS-12	12.0 (.472)	20.0 (.787)	12.0 (.472)	32.0 (1.25)	22.0 (.866)	5.00 (.197)	FOR M4 SOCKET HEAD CAP SCREW
BM-PS-16	16.0 (.630)	26.0 (1.02)		36.0 (1.42)	26.0 (1.02)		
BM-PS-18	18.0 (.709)						
BM-PS-20	20.0 (.787)	30.0 (1.18)	15.0 (.590)	45.0 (1.79)	32.0 (1.26)	6.50 (.256)	M5 SOCKET HEAD CAP SCREW
BM-PS-22	22.0 (.866)						
BM-PS-30	30.0 (1.18)	38.0 (1.50)	18.0 (.709)	55.0 (2.17)	42.0 (1.65)		
BM-PS-36	36.0 (1.42)	44.0 (1.73)		61.0 (2.40)	48.0 (1.89)		
BM-PT-12	M12 x 1	23.0 (.910)	11.0 (.440)	32.0 (1.26)	19.6 (.770)	6.20 (.240)	(2)10- 32x2"
BM-PT-18	M18 x 1	29.3 (1.15)	16.0 (.630)	45.8 (1.80)	30.5 (1.20)	7.60 (.300)	(2)10- 32x2"
BM-MT-12	M12 x 1	25.4 (1.00)	19.2 (.758)	38.1 (1.50)	25.0 (.980)	6.60 (.260)	10-32 SHCS
BM-MT-18	M18 x 1	31.8 (1.25)	25.4 (1.00)	38.1 (1.50)	30.7 (1.21)	3.70 (.145)	8-32 SHCS
BM-MT-30	M30 x 1.5	50.8 (2.00)	33.1 (1.30)	63.5 (2.50)	51.6 (2.03)	5.97 (.235)	1/4 SHCS
BM-MS-12	12.0 (.472)	25.4 (1.00)	19.2 (.758)	38.1 (1.50)	25.0 (.980)	6.60 (.260)	10-32 SHCS
BM-MS-18	18.0 (.709)	31.8 (1.25)	25.4 (1.00)	38.1 (1.50)	30.7 (1.21)	3.70 (.145)	8-32 SHCS
BM-MS-30	30.0 (1.18)	50.8 (2.00)	33.1 (1.30)	63.5 (2.50)	51.6 (2.03)	5.97 (.235)	1/4 SHCS

Block Mounting System™

A modular mounting system The Block Mounting System™ (BMS) consists of clamp-style blocks and components for attaching standard tubular frames and accessories, as well as 40mm cube-style proxies to machine frames.

Features

- Six mounting arrangements
- Fast and simple installation
- Highly interchangeable

Benefits

- Stock mounting solutions
- Wide range of design flexibility
- Secure sensor mounting

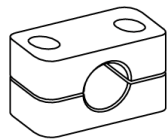

BMS-B
Mounting Block only

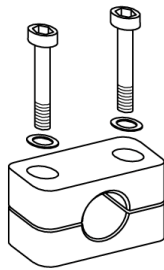

BMS1
with Fasteners

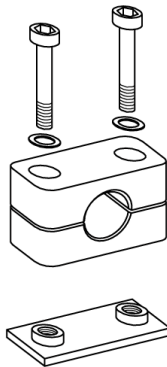

BMS2
with fasteners & Weld Plate

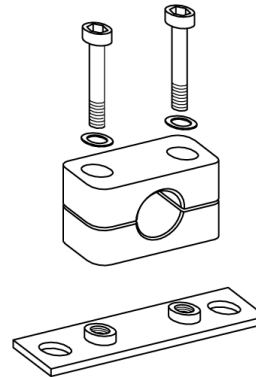

BMS3
with Bolt-on Assembly

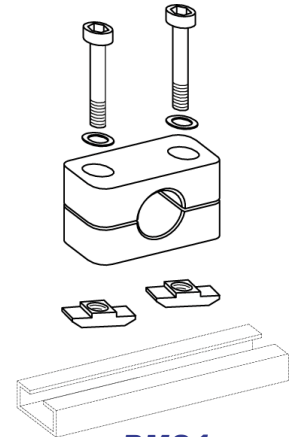

BMS4
with rail nuts for BMS Rail Mounting

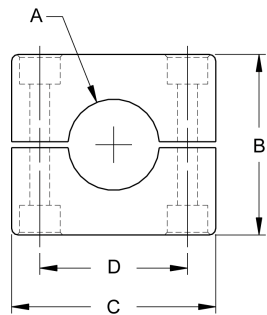

Block

Model No. BMS-B-xx

Model	A	B	C	D
BMS-B-12	11.9 (.469)	27.0 (1.06)	37.0 (1.45)	20.0 (0.79)
BMS-B-16	15.9 (.626)	33.0	42.0	26.0
BMS-B-18	17.9 (.705)	(1.29)	(1.65)	(1.02)
BMS-B-22	21.9 (.862)	36.0	50.0	33.0
BMS-B-24	23.9 (.941)	(1.41)	(1.96)	(1.29)
BMS-B-30	29.9 (1.18)	42.0 (1.65)	59.0 (2.32)	40.0 (1.57)
BMS-B-32	31.9 (1.26)			
BMS-B-36	35.9 (1.41)	58.0 (2.28)	71.0 (2.79)	52.0 (2.04)
BMS-B-40	40 x 40			
BMS-B-47	46.9 (1.85)	66.0 (2.59)	86.0 (3.38)	66.0 (2.59)
Notes	1) All block widths 30.0(1.18) 2) "A" in 40mm version is "square" 3) Material: Polypropylene 4) Other materials and diameters available.			

T-Slot Nut

(Optional BMS4 nut for T-slot mounting)

Model No. TN1-1/4-20

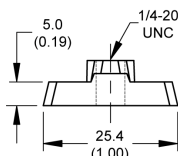
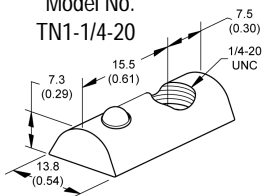

Rail Nut

Model No. BMS-RN-1/4-20

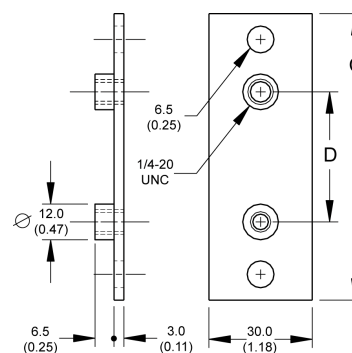

BMS3 - Bolt-on Plate

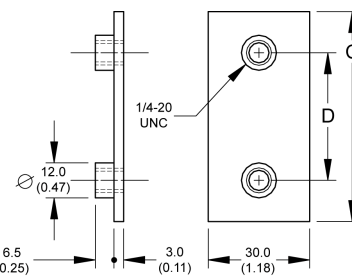

BMS4 - Weld-on Plate

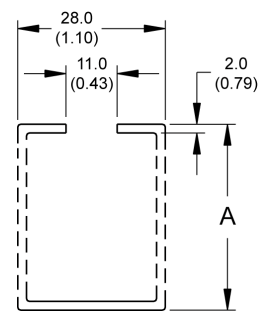

BMSR - Railing

Model	A
BMSR-11	11.0 (.433)
BMSR-30	30.0 (1.18)

Notes: Order in 1 meter or 3 meter lengths, i.e. "BMSR-30-3". Rail and plates are zinc plated mild steel.

Notes/Model Numbers:

- 1) BMS3-30, 30mm block with bolt-on hardware.
- 2) BMS4TN1-30, 30mm block mount with (2) T-nuts to fit most 30 thru 90 series extruded aluminum profiles.
- 3) Order railing section separately.

Flat Brackets

Select multi-slotted FRAB models for maximum sensor adjustment without shimming or machinery modifications, or specify FB type brackets that limit adjustment potential.

Features

- Multi-slotted or limited adjustability models
- Brackets are sized proportionally to sensor
- Zinc-plated CRS & 303 stainless steel options

Benefits

- Eliminate design hassles, source from our stock
- Easy to use with positioning flexibility
- Industry standard mounting footprints



FRAB

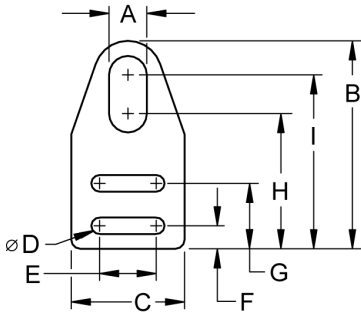

Model	A	B	C	D	E	F	G	H	I
FRAB-08	8.10 (.319)	54.3 (2.14)	31.7 (1.25)	5.60 (.220)	15.9 (.625)	7.14 (.281)	19.0 (.749)	38.7 (1.52)	46.2 (1.82)
FRAB-12	12.1 (.476)	69.9 (2.75)	38.1 (1.50)		19.1 (.750)	7.92 (.312)	22.2 (.875)	45.7 (1.80)	58.4 (2.30)
FRAB-16	16.1 (.634)							43.7 (1.72)	54.1 (2.13)
FRAB-18	18.1 (.713)	82.6 (3.25)	44.5 (1.75)		25.4 (1.00)	7.92 (.312)	22.2 (.875)	50.8 (2.00)	66.7 (2.63)
FRAB-22	22.1 (.870)			49.1 (1.94)				65.0 (2.56)	
FRAB-24	24.1 (.949)			43.7 (1.72)				54.1 (2.13)	
FRAB-30	30.1 (1.18)	105 (4.11)	57.2 (2.25)	34.8 (1.37)	10.3 (.406)	30.9 (1.22)	49.0 (1.93)	61.2 (2.14)	
FRAB-36	36.1 (1.42)						68.6 (2.70)	78.0 (3.07)	
FRAB-47	47.1 (1.85)						135 (5.32)	63.4 (2.50)	38.1 (1.50)
Notes	1) Dimensions are in mm(inch). 2) Models listed are zinc-plated carbon steel. For 303 stainless steel add "-SS" after each model number, for example; FRAB-12-SS. 3) Material thickness on 8-24mm models is 1.78(.070), 30 and 36mm is 2.16(.095) and 47mm is 3.05(.120). 4) See next page for 90 degree angle brackets.								



AB

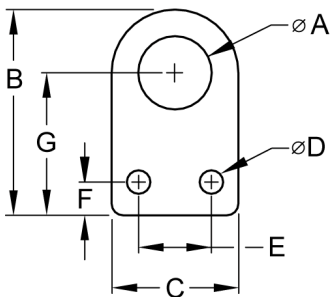
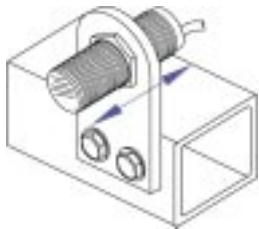

Model	A	B	C	D	E	F	G	Notes
FB-12	12.1 (.476)	48.8 (1.92)	31.8 (1.25)	5.50 (.216)	19.1 (.750)	11.9 (.470)	32.9 (1.30)	1) Dimensions mm(inch). 2) Material is 303 stainless steel. 3) Material thickness for all models is 3.05(.120). 4) See next page for 90 degree angle brackets. 5) SoftNoze will gladly design, quote and or stock your custom bracket requirements.
FB-16	16.1 (.634)							
FB-18	18.1 (.713)							
FB-22	22.1 (.870)	58.4 (2.30)	38.1 (1.50)	6.12 (.241)	25.4 (1.00)	7.37 (.290)	41.4 (1.63)	
FB-24	24.1 (.949)	87.1 (3.43)	50.8 (2.00)	9.93 (.312)	31.8 (1.25)	9.53 (.375)	61.4 (2.42)	
FB-30	30.1 (1.18)							
FB-36	36.1 (1.42)							
FB-47	47.1 (1.85)	103 (4.05)	63.5 (2.50)	10.0 (.394)	38.1 (1.50)	14.5 (.570)	71.1 (2.80)	

Angle Bracket

Select multi-slotted RAB models for maximum sensor adjustment without shimming and machinery modifications, or specify AB type brackets that limit adjustment potential.

Features

- Multi-slotted or limited adjustability models
- Brackets are sized proportionally to sensor
- Zinc-plated CRS or 303 stainless steel

Benefits

- Eliminate design hassles, source from our stock
- Easy to use with positioning flexibility
- Industry standard mounting footprints

Model	A	B	C	D	E	F	G	H	I	J	K	
RAB-08	8.10 (.319)	25.4 (1.00)	31.8 (1.25)	5.54 (.218)	15.9 (.625)	7.14 (.281)	19.0 (.749)	31.8 (1.25)	9.83 (.387)	7.62 (.300)	7.95 (.313)	
RAB-12	12.1 (.476)	38.1 (1.50)	38.1 (1.50)		19.1 (.750)	7.92 (.312)	22.2 (.875)	34.8 (1.37)	14.0 (.550)	12.7 (.500)	11.4 (.450)	
RAB-16	16.1 (.634)				16.3 (.642)				8.10 (.319)			
RAB-18	18.1 (.713)	50.8 (2.00)	44.5 (1.75)		17.4 (.685)				15.9 (.625)	15.9 (.625)		
RAB-22	22.1 (.870)				23.0 (.907)				17.5 (.690)			
RAB-24	24.1 (.949)				9.90 (.390)				17.5 (.689)			
RAB-30	30.1 (.319)	63.5 (2.50)	57.2 (2.25)	7.13 (.281)	34.8 (1.37)				10.3 (.406)	30.9 (1.22)	44.5 (1.75)	19.1 (.750)
RAB-36	36.1 (.319)				32.0 (1.25)	6.40 (.252)	23.9 (.941)					
RAB-47	47.1 (.319)	88.9 (3.50)	63.5 (2.50)		38.1 (1.50)	12.7 (.500)	34.9 (1.38)	50.8 (2.00)	38.1 (1.50)	19.1 (.750)	31.8 (1.25)	
Notes	1) Dimensions are in mm(inch). 2) Models listed are zinc-plated carbon steel. For 303 stainless steel add "SS" after each model number, for example; RAB-12-SS. 3) Material thickness on 8-24mm models is 1.78(.070), 30 and 36mm is 2.16(.095) and 47mm is 3.05(.120). 4) SoftNoze will gladly design, quote and or stock your custom requirements.											

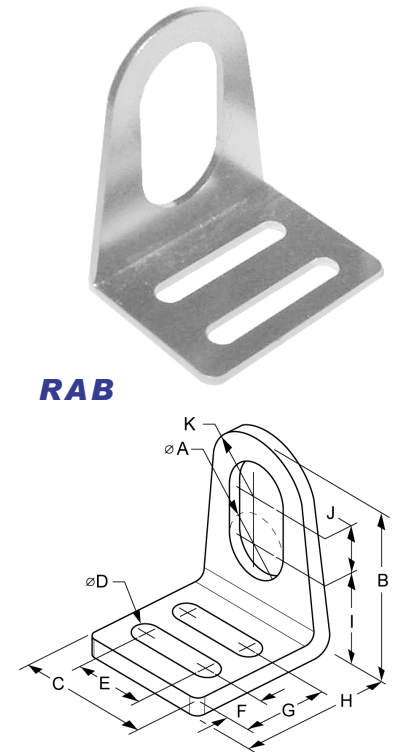

Model	A	B	C	D	E	F	G	H	Notes
AB-12	12.1 (.476)	28.6 (1.13)	31.8 (1.25)	5.50 (.216)	19.1 (.750)	11.9 (.470)	25.4 (1.00)	13.5 (.530)	1) Dimensions mm(inch). 2) Material is 303 stainless steel. 3) Material thickness for all models is 3.00(.118). 4) SoftNoze will gladly design, quote and or stock your custom bracket requirements.
AB-16	16.1 (.634)								
AB-18	18.1 (.713)								
AB-22	22.1 (.870)	38.5 (1.52)	38.1 (1.50)	6.12 (.241)	25.4 (1.00)	7.37 (.290)	25.4 (1.00)	19.8 (.781)	
AB-24	24.1 (.949)								
AB-30	30.1 (1.18)								
AB-36	36.1 (1.42)	54.3 (2.14)	50.8 (2.00)	7.92 (.312)	31.8 (1.25)	9.53 (.375)	38.0 (1.50)	28.6 (1.13)	
AB-47	47.1 (1.85)	70.0 (2.76)	63.5 (2.50)	10.0 (.394)	38.1 (1.50)	14.5 (.570)	38.0 (1.50)	38.1 (1.50)	

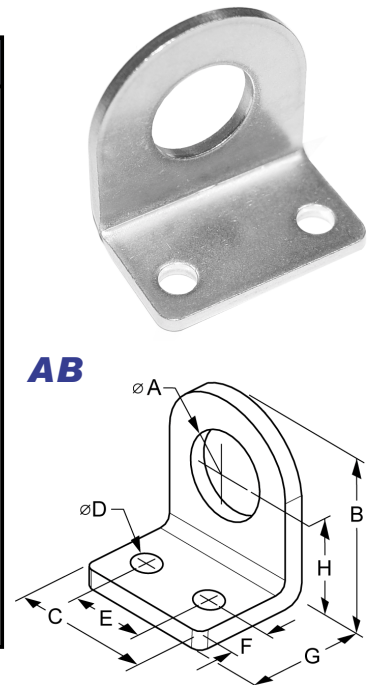

Next Generation Electro-mechanical Connections

Sensors, cordsets and mounting brackets use to be separate devices, but not anymore!

Starting today, EMC Technology™ ushers in the automation industry's next generation of connectivity.

With SoftNoze “EMC™ Host Brackets and Cordsets” an integrated system is created around your favorite sensors. Together these three components become a modular system, one that is elegant, straightforward and packed with value. Proving Albert Einstein's quote once again, “The best design is the simplest one that works.”

EMC Technology™ solutions address everyone's concerns, including- low cost, installation time, adjustability, physical protection, aiming and quick, toolless, change-out.

Move beyond yesterday's separate components (read “higher cost”), where the cordset's coupling nut only engages the sensor for a control signal. EMC Technology™ introduces a totally new design whereby the coupling nut serves the dual and simultaneous function of making not just the electrical connection, but also the final mechanical connection.

Inductive, photoelectric, capacitive, ultrasonic, regardless of type and shape, if it has a cordset, we have a solution. Contact SoftNoze today and learn just how easy it is to implement EMC Technology™ into your next sensor application.

EMC Technology™ eliminates the fasteners typically required to mechanically attach sensors, allowing your machine designs to have the fewest number of components. You will benefit by:

- Reduced manufacturing & assembly costs
- Improved fit, finish and quality
- Faster time-to-market

Connect and disconnect sensors in one easy step.*

*Electrically & Mechanically!

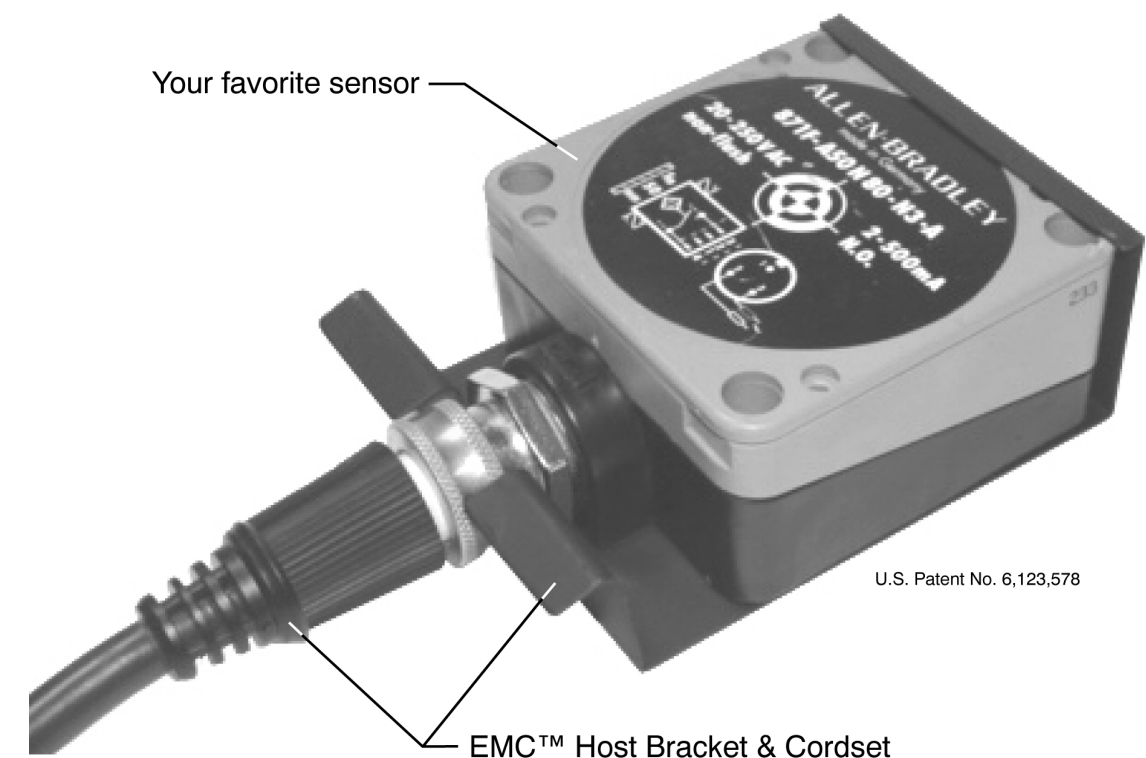

With EMC Technology™ sensor installations may never get easier.

www.softnoze.com/emc

Your Proximity Sensors
+ EMC Technology™
Ultimate Sensor Applications

Sensor Caps, EndNozes™ & Ceramic Faces

Abrasion protection products protective caps and faces eliminate the top reason for sensor failure, abrasion! Caps and faces can make the difference between uptime and downtime.

Features

- Wide variety of protective materials
- Thread-on caps or epoxy-on faces
- For shielded & non-shielded sensors
- Teflon® models for Quicktubes™

Benefits

- Reduces and or eliminates abrasion damage
- Lower downtime & sensor replacement expenses
- Quick solution to costly problems
- Reduce spare sensor inventories



EndNoze™ Caps- Are beveled and designed for use with our Cushioned Sensor Mounts with side approaching targets, see page 4-6. Shielded style EndNoze caps are glass-filled nylon, while non-shielded versions are Delrin®. Caps simply thread-on for easy abrasion protection. Replace just the cap when wear becomes excessive, not your sensor!

Model	A	B	C	D	E	F
EN-08	M8 x 1	15.2 (.600)	5.28 (.210)	0.38 (.015)	6.45 (.250)	NA
EN-08N		14.5 (.570)	5.08 (.200)			9.50 (.370)
EN-12	M12 x 1	24.4 (.960)	6.35 (.250)	0.76 (.030)	11.4 (.450)	NA
EN-12N		22.9 (.900)	6.35 (.250)			17.3 (.680)
EN-18	M18 x 1	31.3 (1.23)	8.38 (.330)	0.76 (.030)	17.5 (.730)	NA
EN-18N		34.0 (1.34)	8.38 (.330)			17.8 (.700)
EN-30	M30 x 1.5	43.7 (1.72)	7.62 (.300)	1.02 (.040)	29.2 (1.15)	NA
EN-30N		44.5 (1.75)	7.87 (.310)			22.9 (.900)



For shielded sensors
EN-xx

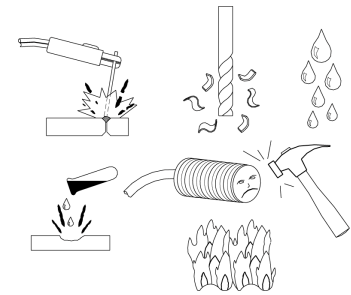
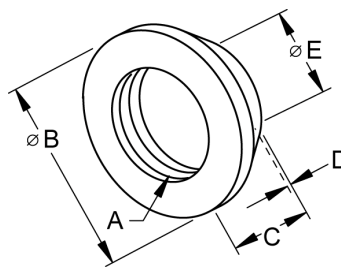

For non-shielded sensors
EN-xx N

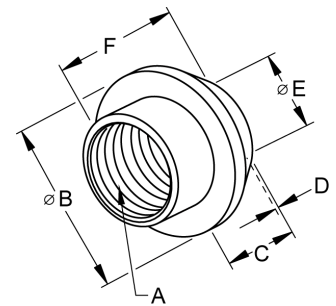

Sensor Caps- Specify material type, add "D" for Delrin, "T" for Teflon® and "C" for ceramic. Ceramic caps are stocked for shielded sensors only. Model number example; SC-12-T.

Model	A	B	C	D
SC-12	M12 x 1	14.7 (0.58)	8.90 (0.35)	0.89 (.035)
SC-12N			15.2 (0.60)	
SC-18	M18 x 1	24.1 (0.95)	8.90 (0.35)	1.14 (.045)
SC-18N			17.8 (0.70)	
SC-30	M30 x 1.5	38.1 (1.50)	9.90 (0.39)	2.03 (0.08)
SC-30N			25.4 (1.00)	

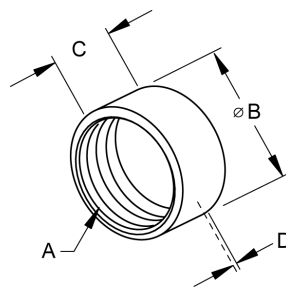

SC & QTC style caps

Quicktube™ Caps- Teflon protection for Quicktubes (see pg. 6) in welding applications.

Model	A	B	C	D
QTC-08-T	M12 x 1	14.7 (0.58)	8.89 (0.35)	0.89 (.035)
QTC-12-T	M16 x 1	19.1 (0.75)	7.11 (0.28)	1.02 (.040)
QTC-18-T	M24 x 1.5	28.4 (1.12)	8.89 (0.35)	1.27 (.050)
QTC-30-T	M36 x 1.5	41.1 (1.62)	8.89 (0.35)	1.78 (.070)

Ceramic Faces- Bonds to sensor face. Epoxy available, order p/n **"CFE-100"**.

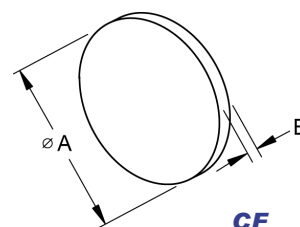

CF

Model	A	B
CF-08	5.80 (0.23)	0.30 (.012)
CF-12	10.4 (0.41)	
CF-18	15.2 (0.60)	0.50 (.020)
CF-30	27.9 (1.10)	

Note- The wear surface thickness, dimension "D" ("B" on Ceramic Faces) does not reduce a sensor's sensing range, but will consume an equal amount of the gap between the sensor and target.

Covers, Shields, Face Plates & Deflectors

Simple steps to help protect your sensors- SoftNoze offers a complete series of protective covers, faces and material deflectors to insure your sensors avoid damage that leads to costly replacement expenses and downtime. Stop abrasion and debris build up to increase the reliability of sensors in harsh manufacturing environments.

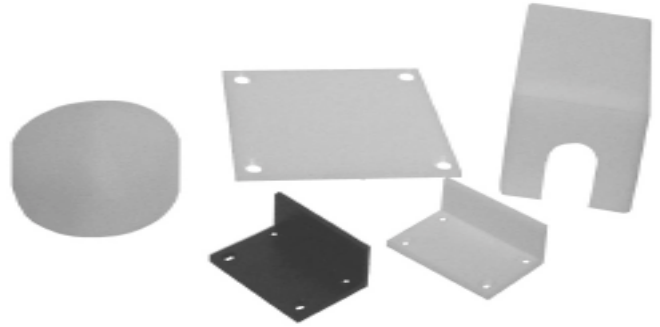

Features

- Offers an abrasion and or solvent resistant surface(s)
- Wide variety of styles and sizes
- Fabricated from various material types

Benefits

- Eliminates abrasion and or corrosion damage
- Ends downtime and replacement expenses
- Increases sensor reliability and operating life

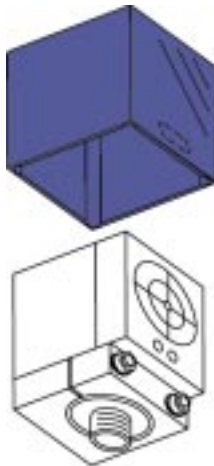

Teflon® Press fit
Housing Covers

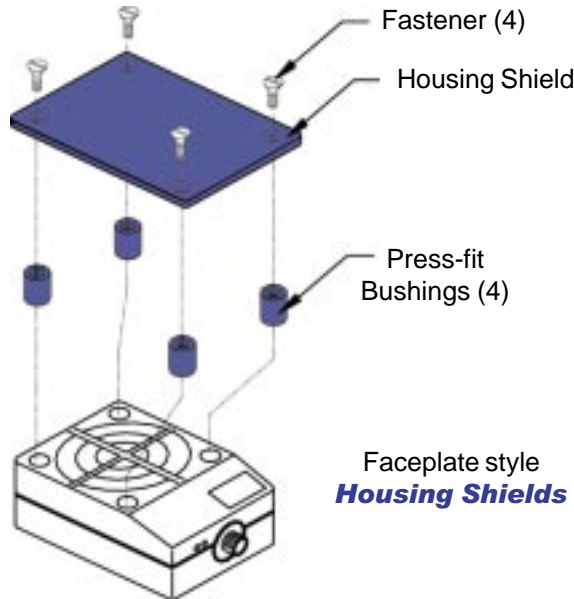

Fastener (4)
Housing Shield
Press-fit Bushings (4)
Faceplate style
Housing Shields

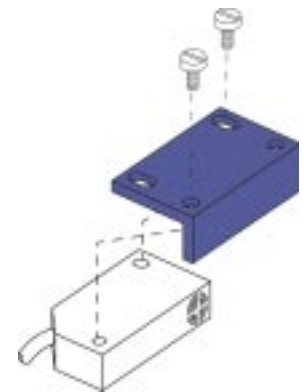

Angled style
Housing Shields

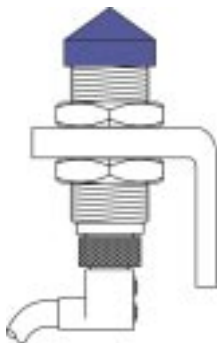

Thread-on
Material Deflectors



Adhesive-backed
Material Deflectors



Brass thread-on
Housing Shields

Ordering: Too many models to show here, please call for specification sheets. Please be ready to offer the sensor's model number and brand, as well as a description of the operating environment. Or, see pages 42 and 43 for further information on submitting application specific requirements to SoftNoze.

WeldJacket™ & WeldJacket Pro™



WeldJacket™ & WeldJacket Pro™ cable and connector protection for welding applications Even the finest cables and connectors fall prey to the extreme heat, molten metal and abrasion found in welding environments. Simply slide WeldJacket over your cables and cordsets to protect them from weld slag buildup, heat bursts, environmental debris and abrasion

Features

- Two styles of woven fiberglass
- Two sizes for Mini & Micro cordsets
- 36" lengths or 25' spool

Benefits

- Weld slag & extreme heat protection
- Reduces downtime and replacement expenses
- Increases sensor reliability and connector life

Shield cables and their connectors from the damaging elements in extreme manufacturing environments. WeldJacket™ and WeldJacket Pro™ protects cordsets from conditions that would otherwise deteriorate and make cables brittle, less reliability and serviceable.

Specifications					
WeldJacket™			WeldJacket Pro™		
Model	Diameter	Length	Model	Diameter	Length
WJ-12-900	12.7mm (1/2")	91cm(36")	WJP-12-900	12.7mm (1/2")	91cm(36")
WJ-12-15K		1,524cm(50')	WJP-12-15K		1,524cm(50')
WJ-19-900	19.1mm (3/4")	91cm(36")	WJP-19-900	19.1mm (3/4")	91cm(36")
WJ-19-15K		1,524cm(50')	WJP-19-15K		1,524cm(50')
Description					
Non-fraying oversleeve that is flexible, high-temperature secondary insulation made from closely braided, continuous filament Fibreglas® which has been heat-cleaned to remove impurities in the yarn and to retard fraying. Treated with an acrylic resin binder (natural or pigmented). Binders are applied to further retard fraying and to hold sleeving round for cutting. Will serve as secondary insulation			Woven fiberglass sleeving coated with a specially formulated and proprietary silicone rubber. Exhibits exceptional high-temperature properties, flexibility, and toughness and abrasion resistance. Silicone rubber finish provides superior thermal protection, flame resistance and makes it an ideal choice for welding applications requiring outstanding physical and insulation properties in high operating temperatures.		
Thermal Endurance					
-60°C to +316°C (-140°F to +600°F), up to 316°C indefinitely and up to 616°C for shorter periods.			-80°C to +240°C (-112°F to +464°F)		
Chemical Endurance					
1) Resistance to Acids and Alkalis: good resistance to most alkalis, resistance to acids is fair. 2 Effect of Bleaches and Solvents: unaffected 3) Resistance to mildew, aging and sunlight: excellent resistance to sunlight and aging, not attacked by mildew.			1) Oil and Solvent Resistance: passes MIL-I-3190/9 2) Water Vapor Resistance: passes MIL-I-3190/9 3) Resistance to Acids and Alkalis: excellent 4) Resistance to mildew, aging and sunlight: unaffected by sunlight and weather. 5) Compatibility UL 1446 Good. Compatible with most varnishes		
Standards					
Conforms to NEMA TF-2 and UL® 1441 VW-1 flammability requirements.			Exceeds the requirements of UL 1441- table 19.8, NEMA TF-1- type 5 and ASTM-D372.		

Optical Fiber Protection Add an additional layer of protection to plastic optical fibers by simply slide FiberJacket™ over fiber for an additional strength and durability.

Features

- Three jacket types & field-installable
- Three sizes for 3, 4 & 6mm fibers
- Threaded or compression fittings

Benefits

- Protects fibers from damage
- Field-installable
- Increases fiber reliability and life



Specifications						
Model	Core fiber diameter		Description	O.D.	Length	
FJ-952-PVC	Bifurcated	1mm (.040") or 1.5mm (.060")	PVC sheathing with plastic compression fittings at each end	9.5mm	2 meters (6 feet) Custom lengths are available, call factory	
	Individual	N/A				
FJ-642-PVC	Bifurcated	0.25mm (.010") or 0.5mm (.020")		6.4mm		
	Individual	1.0mm (.040") or 1.5mm (.060")				
FJ-402-PVC	Bifurcated	N/A		4.0mm		
	Individual	1.0mm (.040") or 1.5mm (.060")				
FJ-692-SSC	Bifurcated	1mm (.040") or 1.5mm (.060")		Stainless steel with plastic compression fittings at each end		6.9mm
	Individual	N/A				
FJ-532-SSC	Bifurcated	0.25mm (.010") or 0.5mm (.020")				5.3mm
	Individual	1.0mm (.040") or 1.5mm (.060")				
FJ-442-SSC	Bifurcated	N/A				4.4mm
	Individual	1.0mm (.040") or 1.5mm (.060")				
FJ-692-SST	Bifurcated	M6 x 0.75 fiber tip	Stainless steel with one end internally threaded to attach to fiber tips and the other end non-threaded		6.9mm	
	Individual	N/A				
FJ-532-SST	Bifurcated	M4 x 0.7 fiber tip			5.3mm	
	Individual					
FJ-442-SST	Bifurcated	N/A			4.4mm	
	Individual	M3 x 0.5 fiber tip				

Conduit & Threaded Adapters, Weld Flanges

Conduit Adapters

A must when wiring codes require tubular proximity sensor cables to be protected using conduit.

Features

- Round steel or Hex aluminum styles
- Fully threaded to accommodate all sensors
- Sizes for 12, 18 and 30mm sensors

Benefits

- Protect sensor cables from damage
- Meet wiring codes with ease
- Stock solutions for your sensor applications

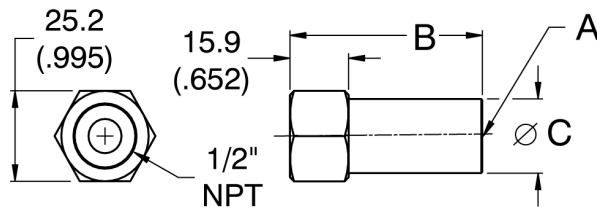
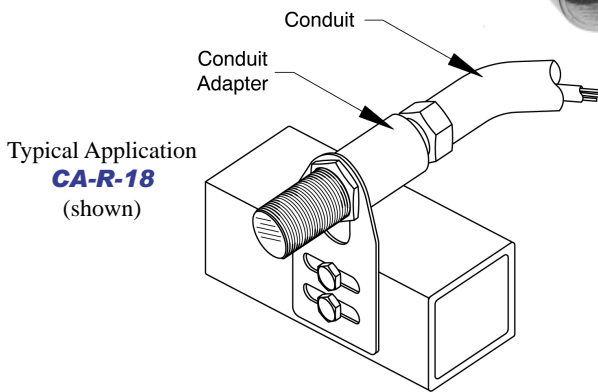

Model	A	B	C	Notes
CA-R-12	M12 x 1	50.1 (1.97)	17.5 (0.69)	1) Dimensions mm(inch). 2) Material is Zinc plated CRS. 3) SoftNoze will gladly design, quote and or stock your custom requirements.
CA-R-18	M18 x 1	55.5 (2.18)	21.4 (0.84)	
CA-R-30	M30 x 1.5	68.2 (2.68)	33.3 (1.31)	

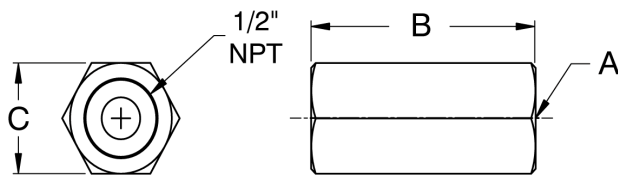

Model	A	B	C	Notes
CA-H-12	M12 x 1	50.1 (1.97)	25.4 (1.00)	1) Dimensions mm(inch). 2) Material 6061 Aluminum, no finish. 3) SoftNoze will gladly design and quote your other requirements.
CA-H-18	M18 x 1	55.5 (2.18)		
CA-H-30	M30 x 1.5	68.2 (2.68)	34.9 (1.37)	

Custom Modification Fasteners

Use for modifications or just as replacement parts. SoftNoze is committed to sweating the small stuff so you'll be successful. Contact us if you need unique fasteners to compliment your sensors, we're here to assist you!

Threaded Adapters- help make sensor and control conversions possible, and easy.

Model	A	B	C	D	E
TAN-08-12	M 8 x 1	M 12 x 1	9.53 (0.38)	5.54 (0.22)	15.9 (0.62)
TAN-08-12L			22.2 (0.88)		
TAN-12-18	M 12 x 1	M 18 x 1	9.53 (0.38)	6.35 (0.25)	22.2 (0.88)
TAN-12-18L			22.2 (0.88)		
Notes:	1) Materials: Nut, plated brass and sleeve, plated CRS 2) To order without jam nuts, eliminate the "N" from the model numbers shown, for example; TA-08-12.				

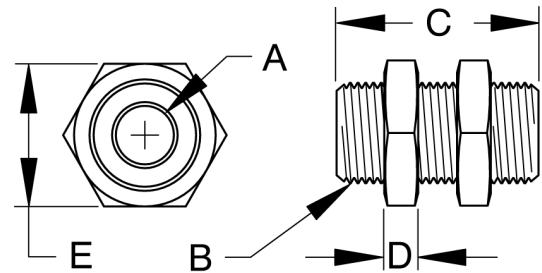

Weld Flanges- weld onto tank walls for attachment of threaded (NPT and SAE) Sensor Wells.

Model	A	B	C	D
WF-050-NPT	1/2 NPT	28.7 (1.13)	44.5 (1.75)	16.0 (0.63)
WF-075-NPT	3/4 NPT	34.9 (1.38)	54.0 (2.13)	17.5 (0.69)
WF-125-NPT	1-1/4 NPT	50.8 (2.00)	68.3 (2.69)	19.1 (0.75)
WF-150-NPT	1-1/2 NPT	57.2 (2.25)	76.2 (3.00)	
WF-12-SAE	SAE-12	34.9 (1.38)	54.0 (2.13)	17.5 (0.69)
Materials:	Forged steel alloy			

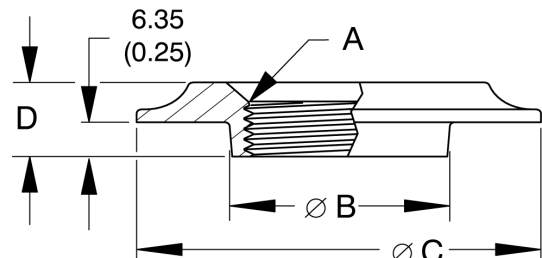

ProxPort™ Mount & Conversion Brackets

Conversion Brackets - Helpful when upgrading from one sensor or switch to another. Two popular models give tubular sensors bolt pattern of common limit switches and SoftNoze also make customs:

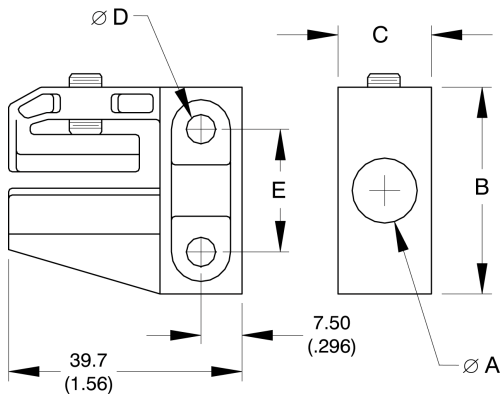
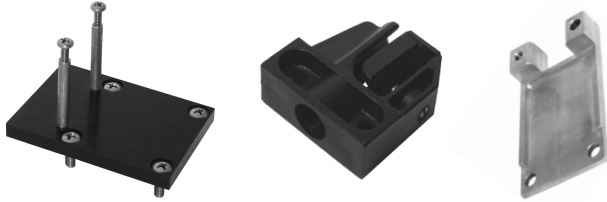

Model	A	B	C	D	E
CB-5000	12.1 (.476)	40.0 (1.57)	16.0 (.630)	5.40 (.213)	25.0 (.985)
CB-6000	18.1 (.712)	45.0 (1.77)	22.0 (.866)	5.60 (.220)	30.0 (1.18)
Notes	1) Dimensions are in mm(inch). 2) Material is glass-filled Nylon with stainless steel set screw.				

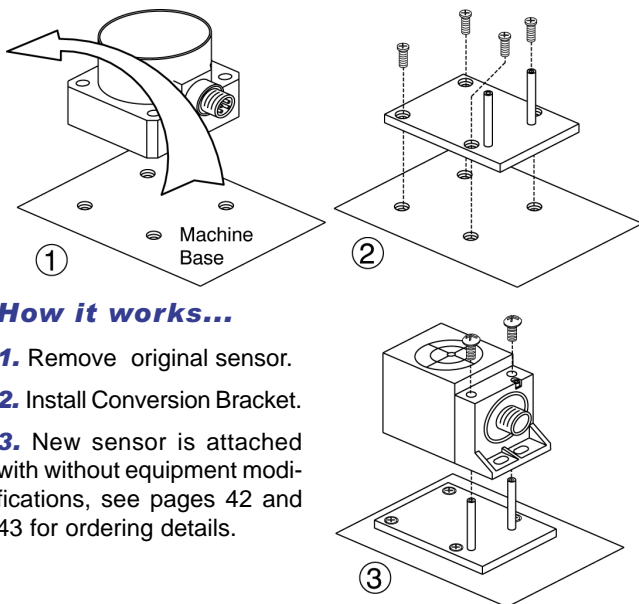

How it works...

1. Remove original sensor.
2. Install Conversion Bracket.
3. New sensor is attached with without equipment modifications, see pages 42 and 43 for ordering details.

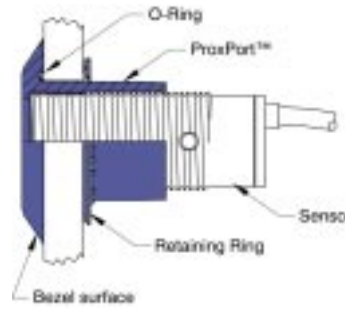

ProxPort "PM" The Panel Mount is inserted into a clearance hole and locked into place with a retaining ring. The sensor is then threaded into the mount resulting in a neat bezel-type appearance.

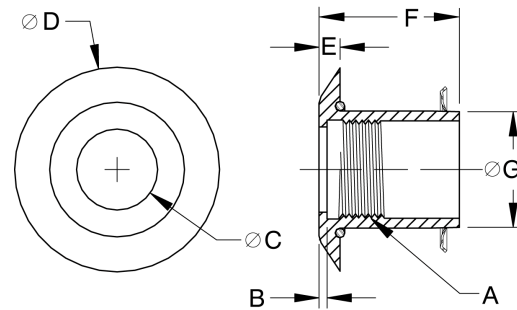

Model	A	B	C	D	E	F	G
PPPM-12	M12 x 1	1.26 (.050)	10.4 (.409)	38.0 (1.50)	3.73 (.147)	25.4 (1.00)	15.9 (.625)
PPPM-18	M18 x 1		16.6 (.656)	44.5 (1.75)	3.75 (.147)		22.1 (.870)
PPPM-30	M30 x 1.5	2.30 (.090)	26.0 (1.02)	47.7 (1.88)	5.08 (.200)	38.1 (1.50)	33.3 (1.31)
Notes	1) Dimensions are in mm(inch). 2) Material is Delrin®, black, with a stainless steel retaining ring. 3) Circular assembly tool (i.e. a socket) required for assembly.						

ProxPort™ FL Offers a "twist and pop-up" cartridge design. This "Front-Loading" capability allows a sensor to be positioned below a surface, yet all future sensor maintenance can be completed without going "below the deck"...

Models	
12mm	PPFL-12
18mm	PPFL-18
30mm	PPFL-30
Call for datasheets	

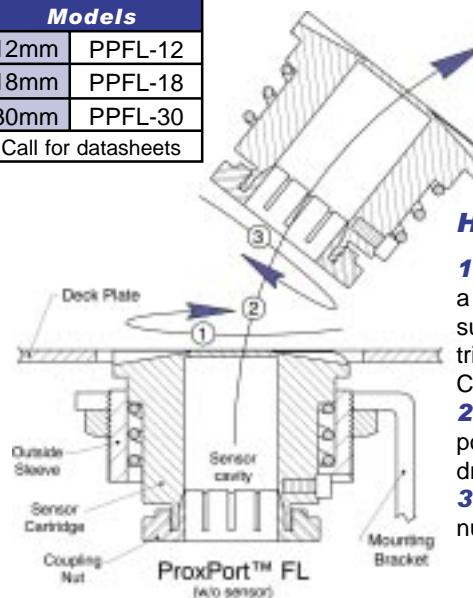

How it works

1. Using finger tips and a slight downward pressure on the sensor cartridge, twist 45° (CW or CCW).
2. Sensor cartridge will pop-up and can be withdrawn.
3. Unscrewing coupling nut to release sensor.

Banking Screw Adapter™



Head-treated Stop Screws

Simply attach any standard shielded proximity sensor to the BSA and create a heavy-duty, solid state switch. Available in 8, 12 and 18mm screw diameters and a wide variety of lengths.



Features

- Heat-treated alloy steel construction
- Mix & match with different sensors
- Optional ball-end piston & spring rates
- Three diameters and many barrel lengths

Benefits

- Stop travel and sense with one device
- Versatile outputs using any shielded sensor
- Isolates sensor from impact damage
- New applications for proximity sensors

Multiple design options

BSA's are configurable to meet your machine design requirements, see below and use the model numbering guide on page 21:

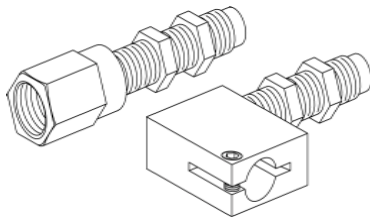

1- Right angle models shorten the overall length and will fit into more confined applications.

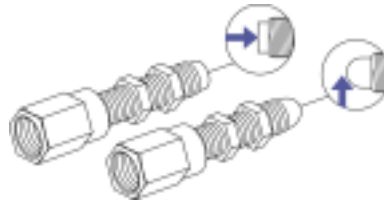

2- Flat pistons are for axial impact forces and ball-end pistons are for laterally moving targets.



3- Use a smaller, larger or the same diameter sensor as the BSA barrel diameter.

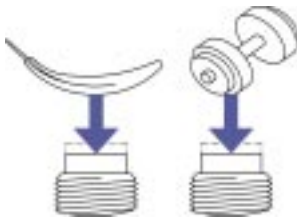

4- Standard models have a light spring rate, but a heavier spring rate is available, see page 21.

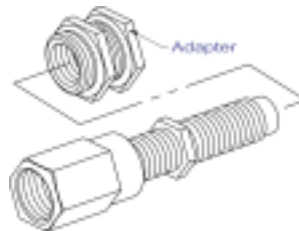

5- Can be supplied with adapters for retrofitting into existing hole/thread locations, see pg. 18.

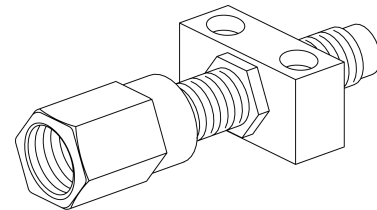

6- Install with a block mount or bracket, see pages 9-13. SoftNoze can bundle products and make specials.

Construction & Operation

Both the screw and piston are heat-treated to withstand heavy use. A connecting rod ties the spring-loaded piston to a metal target, which triggers the sensor upon displacement of the piston. The sensor is separated and thus isolated from impact from the target by a plastic stop bushing. Two heavy-duty jam nuts, or an optional threaded Block Mount, secure the BSA.

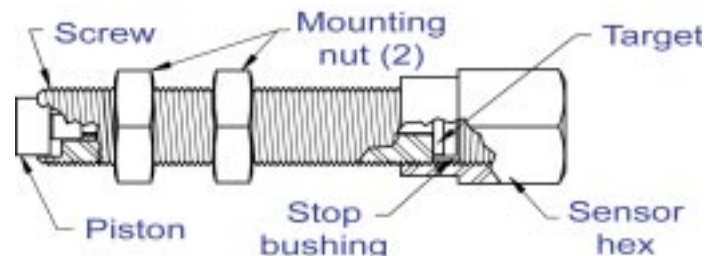

Banking Screw Adapter™

Typical Application

Shown below, a BSA is used as a reliable and rugged stop for a linear slide unit. Accurate and easy adjustments to end of stroke positions are possible using a standard, shielded, prox sensor:

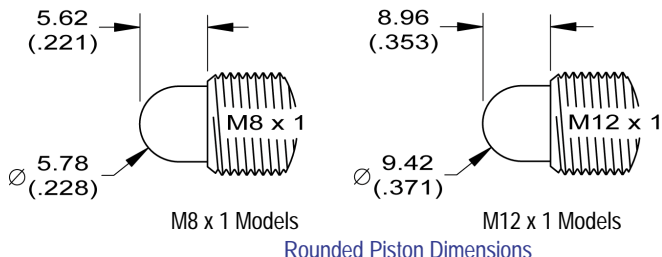
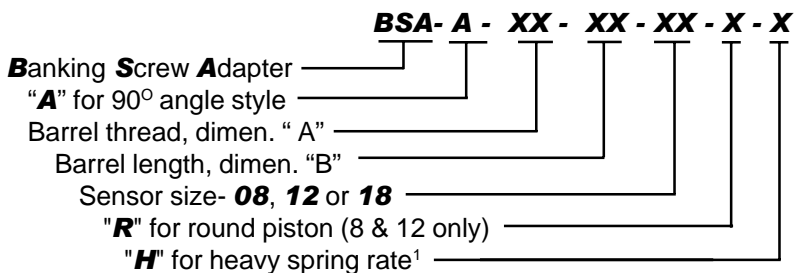
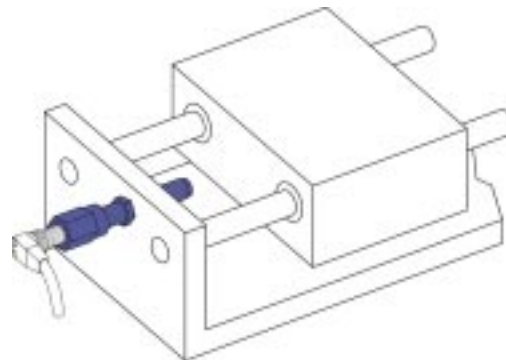

BSA	A	B	C	D	E	F	G...
08-25	M8 x 1	25.0 (0.98)	M8 x 1	3.16 (0.12)	5.84 (0.23)	6.26 (0.24)	...of mounting nut (2):
08-50		50.0 (1.97)	or M12 x 1				M8x1: 12.8 (0.50)
12-25	M12 x 1	25.0 (0.98)	M8 x 1 or M12 x 1 or M18 x 1	4.32 (0.17)	9.40 (0.37)	5.94 (0.23)	M12x1: 15.7 (0.62)
12-50		50.0 (1.97)					M18x1: 22.1 (0.87)
12-75		75.0 (2.95)					...of sensor hex:
12-100		100 (3.94)					M8x1: 11.0 (0.43)
18-25	M18 x 1	25.0 (0.98)	M8 x 1 or M12 x 1 or M18 x 1	14.2 (0.56)	6.36 (0.25)	6.36 (0.25)	M12x1: 15.7 (0.62)
18-50		50.0 (1.97)					M18x1: 22.1 (0.87)
18-75		75.0 (2.95)					
18-100		100 (3.94)					

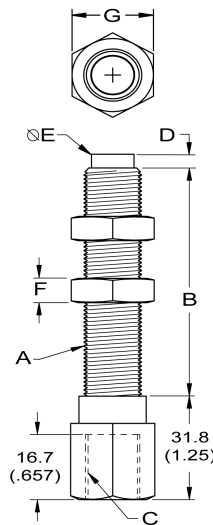

Notes: Dimensions mm(inch). Spring rates; standard models require 252grams(9oz.) for sensor activation and heavy spring rate models 1120 grams(40oz.). Maximum allowable impact force (F') on pistons is; 2 K-N (450 lb-ft) for 8mm models, 20.5 K-N (4.6K lb-ft) for 12mm models and 45 K-N (10.1 K lb-ft) for 18mm models. Calculate by, $F' = M \times A$ where F' is in newtons(N), M (mass) is in kilograms and A (acceleration), in meters/second(m/s). Piston displacement, all models: 1.93(.076). Use only shielded-type proximity sensors.

BSAA	A	B	C	D	E	F	G	H	I	J	K
08-25	M8 x 1	25.0 (0.98)	8mm or 12mm	3.16 (0.12)	5.84 (0.23)	6.26 (0.24)	12.8 (0.50)	17.8 (0.70)	22.2 (0.88)	12.7 (0.50)	25.4 (1.00)
08-50		50.0 (1.97)									
12-25	M12 x 1	25.0 (0.98)	8mm or 12mm	4.32 (0.17)	9.40 (0.37)	5.94 (0.23)	15.7 (0.62)	18.0 (0.71)	25.4 (1.00)	15.9 (0.62)	31.8 (1.25)
12-50		50.0 (1.97)									
12-75		75.0 (2.95)									
12-100		100 (3.94)									
18-25	M18 x 1	25.0 (0.98)	12mm	14.2 (0.56)	6.36 (0.25)	22.1 (0.87)	27.9 (1.10)	25.4 (1.00)	22.2 (0.88)	44.4 (1.75)	
18-50		50.0 (1.97)									
18-75		75.0 (2.95)									
18-100		100 (3.94)									

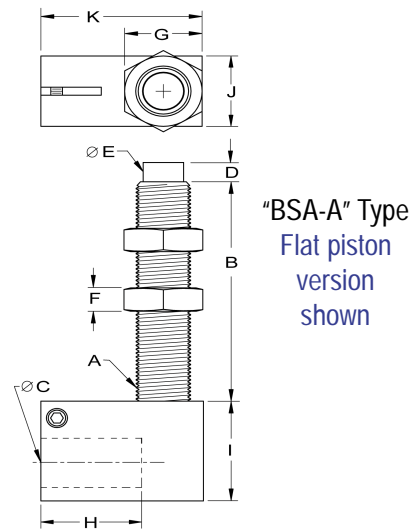

ProxProbe™ Adapter



Convert standard proximity sensors into probe-style switches ProxProbe's "ball end" rod reaches into tight areas and offers a very compact and highly adjustable mechanical sensing device.



Features

- Accepts standard shielded 8 or 12mm sensors
- Spring-loaded probe with Oilite® bearing
- Wide variety of probe lengths and diameters
- Tool steel probe

Benefits

- Accurate and compact sensing
- Rapid installation and simple to adjust
- Reliable and versatile solid-state output
- Offers new control input options

Typical application: Shown at the right, a ProxProbe™ is used to monitor the misfeed punch in a die set. Should a misfeed occur, ProxProbe™ signals the control system to shutdown. Mounting is easy and adjustments are both quick and precise with ProxProbe™.

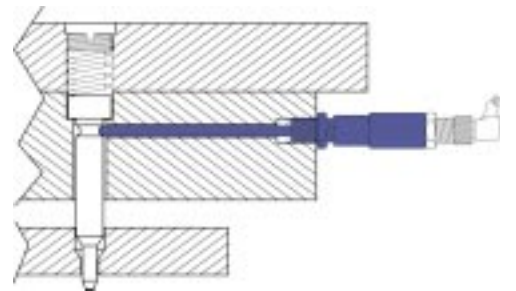

Model	A	B	C	D	E	F	Probe Travel ¹
PPA-08-25-03	75.6 (2.98)	25.4 (1.00)	M8 x 1 to a depth of 20.0 (0.79)	M8 x 1	3.18 (.125)	11.1 (0.44)	Maximum: 1.93 (.076) For activation: varies due to sensor's sensing range, but typically 0.13 (.005) to 0.25(.010) Use a sensor with a standard "shielded" sensing range (S _n = 1mm) for best results.
PPA-08-50-03	99.6 (3.92)	50.8 (2.00)					
PPA-08-75-03	126 (4.96)	76.2 (3.00)					
PPA-08-100-03	150 (5.91)	102 (4.00)					
PPA-12-25-03	75.6 (2.98)	25.4 (1.00)	M12 x1 to a depth of 18.0 (0.71)	M12 x1	3.18 (.125)	15.8 (0.62)	Maximum: 1.93 (.076) For activation: varies due to sensor's sensing range, but typically 0.13 (.010) to 0.38(.015) Use a sensor with a standard "shielded" sensing range (S _n = 2mm) for best results.
PPA-12-50-03	99.6 (3.92)	50.8 (2.00)					
PPA-12-75-03	126 (4.96)	76.2 (3.00)					
PPA-12-100-03	150 (5.91)	102 (4.00)					
PPA-12-25-06	75.6 (2.98)	25.4 (1.00)			6.35 (.250)		
PPA-12-50-06	99.6 (3.92)	50.8 (2.00)					
PPA-12-75-06	126 (4.96)	76.2 (3.00)					
PPA-12-100-06	150 (5.91)	102 (4.00)					

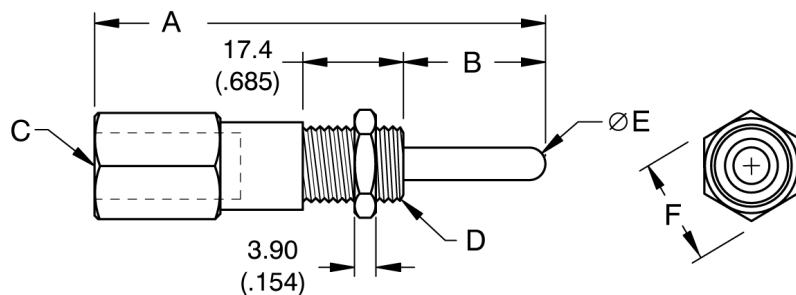

Notes: **1)** Damage to both probe and sensor may result if specified maximum probe travel is exceeded. **2)** Standard ProxProbe™ requires 252grams (9oz.) for sensor activation. Optional "heavy" spring rate requires 1120grams (40oz) to activate sensor (add an "H" to end of model number). **3)** For use with shielded type proximity sensors only. **4)** Thread sensor into ProxProbe™ only until proper "On/Off" triggering is achieved, do not thread sensor in fully or damage will occur. **5)** Custom probes are readily quoted, please contact factory for different lengths, diameters, threading and attachments.

ProxPlunger™ & WeldSwitch™

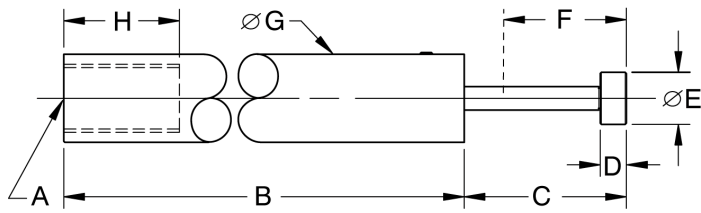

Model	PPL-12-13	PPL-12-25	PPL-12-50	PPL-18-50
A	M12 x 1			M18 x 1
B	130 (5.13)			
C	17.7 (.697)	43.2 (1.70)	55.9 (2.20)	43.2 (1.70)
D	4.70 (.185)			
E	9.27 (.365)			
F	12.7 (0.50)	38.1 (1.50)	50.8 (2.00)	38.1 (1.50)
G	15.9 (.625)			22.2 (.875)
H	15.2 (0.60)			23.1 (0.91)

Notes: **1)** Plunger requires approx. 224grams (8oz.) for initial displacement and sensor activation. **2)** For use with shielded-type proximity sensors only. **3)** Mount with Block Mounts (12 & 22mm versions) on page 11. **4)** Custom designs gladly quoted- please contact factory to discuss options or see pages 42-43.

ProxPlunger™ is a “long stroke” switching device Once installed a standard proximity sensor triggers early in the stroke, but the plunger’s built-in overtravel makes compliance with inaccurate targets a snap.

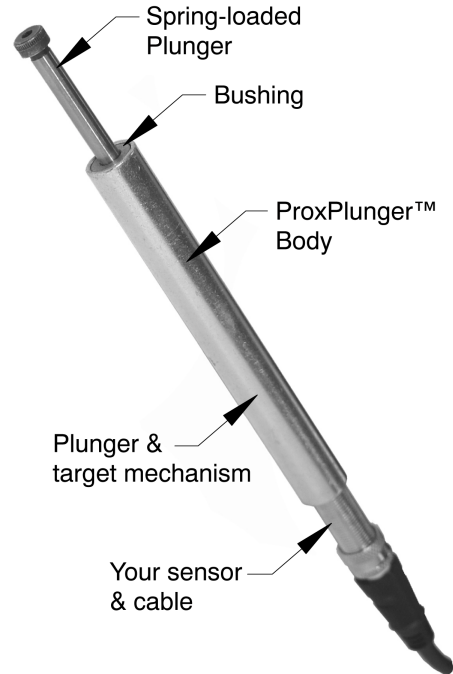

WeldSwitch™ designed for automotive welding cells and other molten-metal applications. WeldSwitch™ functions like our ProxProbe™ Adapter, however WeldSwitch™ offers a more compact design and the plunger (and or body) are manufactured from solid copper. When combined with a standard proximity, WeldSwitch™ becomes a robust and long-life input device that is immune to harsh temperatures and extremely hot metal splatter.

Model	PPLWS-1-12	PPLWS-2-12	PPLWS-3-12
Materials of Construction	Operator: Copper Barrel: CRS/Zinc Housing: Delrin®	Operator: Copper Barrel: Copper Housing: Delrin®	Operator: Copper Barrel: Copper Housing: Copper

Notes: **1)** Plunger requires approximately 224grams (8oz.) for initial displacement and sensor activation. **2)** Sensor activates within ~2.5mm(0.1”) of stroke and then offers 25.4mm(1”) overtravel. **3)** For use with shielded-type proximity sensors only. **4)** Custom designs are readily quoted, please contact factory to discuss options, or see pages 42-43.

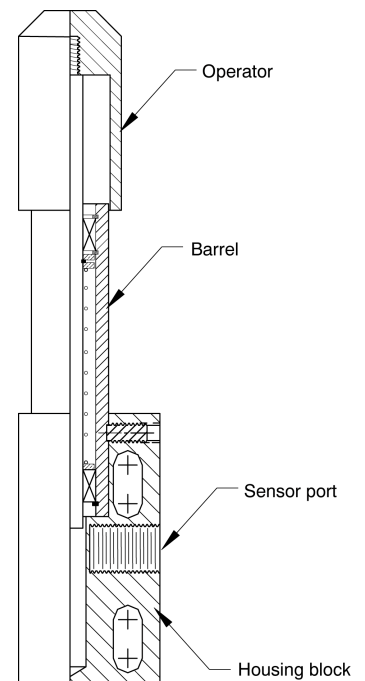
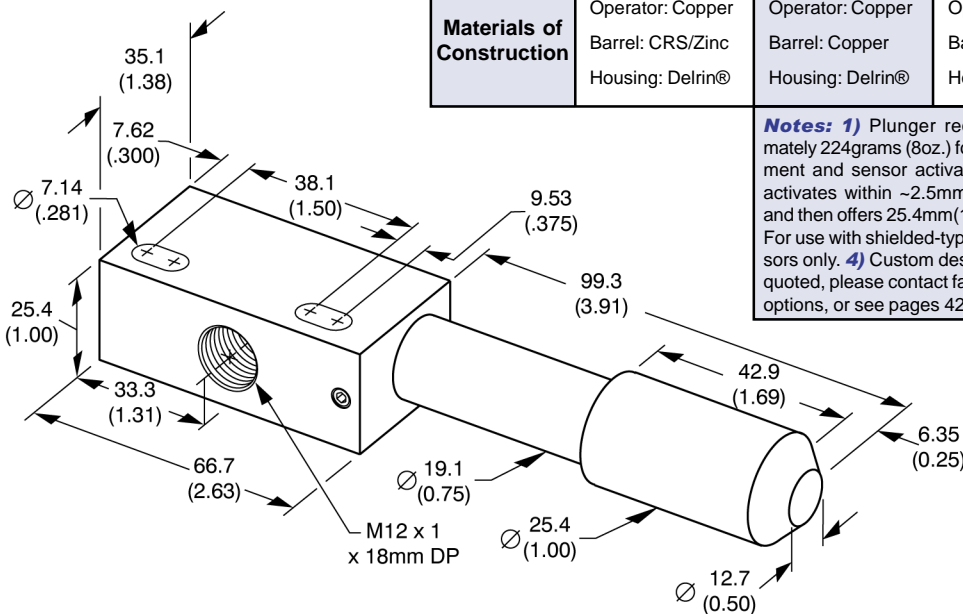

Proxtrol™ Limit Switches (PLS)



PLS-1 type
Full Size



PLS-M type
Mini DIN

Let the controlling begin, with a new solid state switching alternative Now you can design control systems with the conventional simplicity of limit switches, while also taking advantage of commonly proximity sensor technology. Together, with our Proxtrol™ Limit Switch and your favorite prox, you'll now have the best of both worlds. Simply thread your prox into a Proxtrol™ Limit Switch and let the controlling begin!



PLS1 type
Full Size

PLSM type
Mini DIN



Features

- Accepts any shielded 12mm proximity sensor
- Thermoplastic polyester housings
- Wide selection of operating heads
- Meets worldwide dimension standards

Benefits

- Solid state switching - no electric contacts
- Directly replaces traditional limit switches
- Create "network-ready" limit switches
- No wiring, simply thread-in your prox



Proxtrol™
Limit Switch

Plus

Your 12mm
Prox Sensor

- Patent Pending -

Power the Proxtrol™ Limit Switch with your favorite prox!

Proximity sensors are everywhere. However, many applications and situations still call for a time-tested limit switch. Or perhaps you simply like limit switch simplicity? Either way, the Proxtrol™ Limit Switch allows you to blend two proven technologies to achieve new control options.

Have you been planning to upgrade to modern solid state sensing technology, but concerned with the necessary considerations required with non-contact sensors? Set your concerns aside and make the improvements you've been waiting for. No need to redesign, recalculate or reeducate. In fact, you probably already have half the solution (a 12mm prox) in inventory.

When you need a reliable, PLC-friendly input signal, think Proxtrol™ by SoftNoze. The following pages contains our "full size" and "Mini DIN" styles of our expanding line of hybrid limit switches.

Ready to do more with proximity sensors? Just look to Proxtrol™ from SoftNoze.

Description- Each switch consists of a housing and operator head assembly. Purchaser must provide a standard M12x1, shielded type, proximity sensor. Order Proxtrol™ Limit Switches by specifying the model number shown below each operator head below. **Note-** 1) Dimensions of housing and operator heads are shown separately only to save space in this catalog. 2) SoftNoze can modify certain operator heads shown here to your specifications, please call factory.

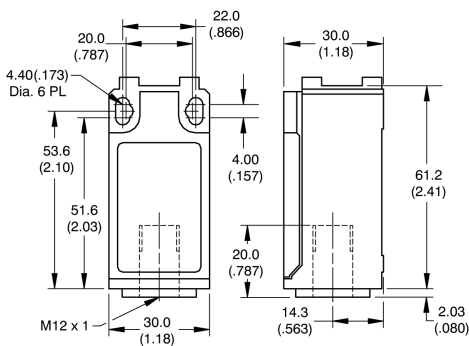

"PLS-M" Housing

Model No.: N/A (Not sold separately)

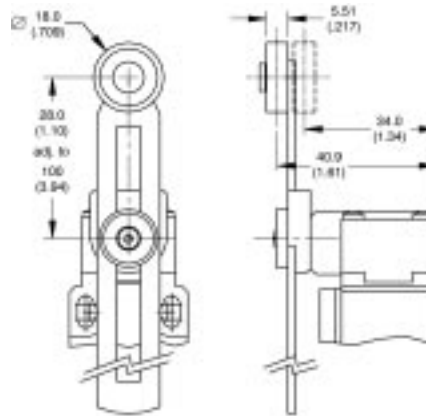

Side Rotary, Adjustable Roller Lever
Model No.: PLS-M-SARL

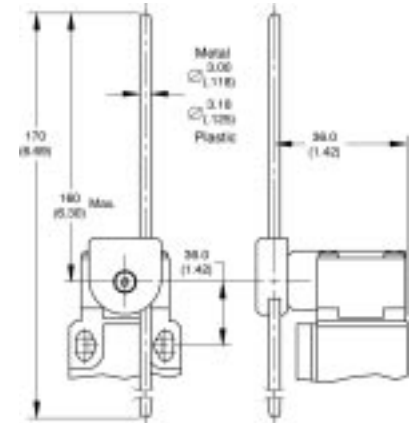

Side Rotary, Metal Rod (Two Models) Model No.: PLS-M-SR-MR
Side Rotary, Plastic Rod Model No.: PLS-M-SR-PR

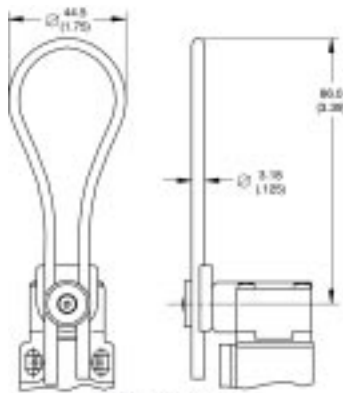

Side Rotary, Plastic Loop
Model No.: PLS-M-SR-PL

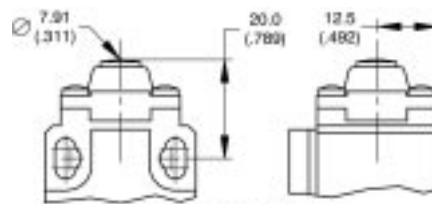

Top Push, Metal Plunger
Model No.: PLS-M-TMP

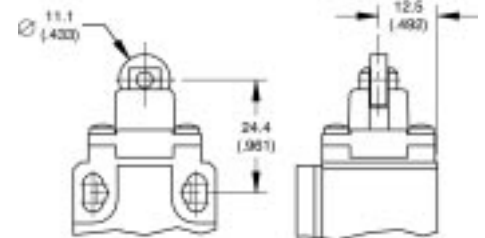

Top Push, Roller Plunger
Model No.: PLS-M-TRP

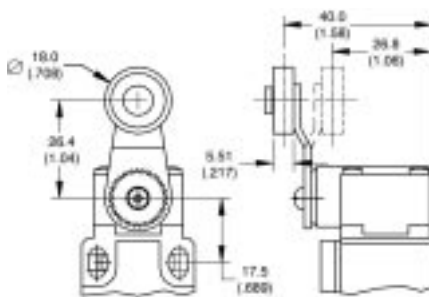

Side Rotary, Roller Lever
Model No.: PLS-M-SRL

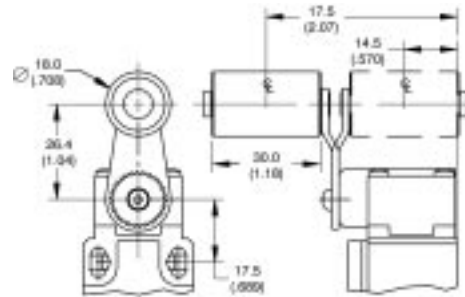

Side Rotary, Wide Roller Lever
Model No.: PLS-M-SRLW

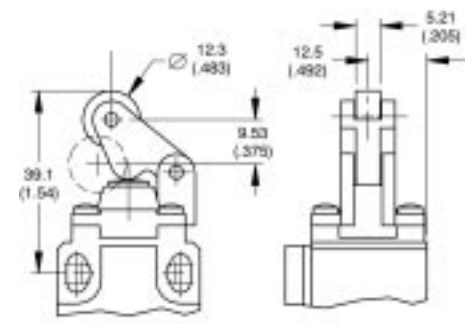

Top Push, Roller Lever
Model No.: PLS-M-TRL

Description- Each switch consists of a housing and operator head assembly. Purchaser must provide a standard M12 x 1 shielded, tubular proximity sensor. Order Proxtrol™ Limit Switches by specifying model numbers as shown below each operator head below. **Note-** Dimensions of housing and operator heads are shown separately only to save space in this catalog. SoftNoze can modify certain operator heads shown here to your specifications, please call factory.

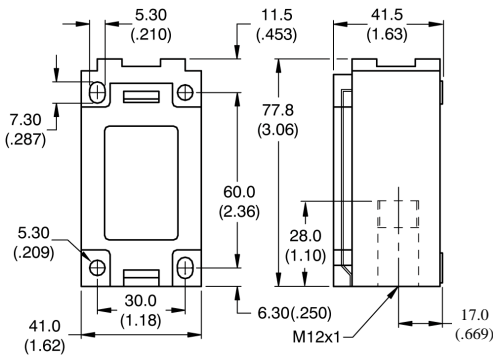

"PLS-1" Housing

Model No.: N/A (Not sold separately)

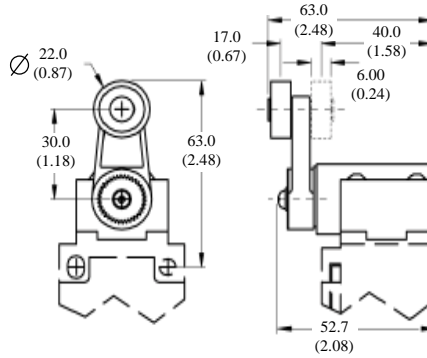

Side Rotary, Roller Lever

Model No.: **PLS-1-SRL**

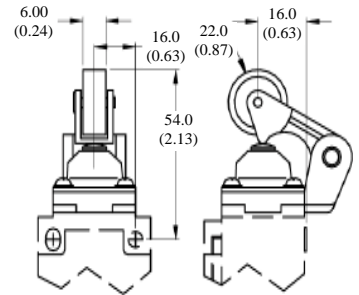

Top Push, Roller Lever

Model No.: **PLS-1-TRL**

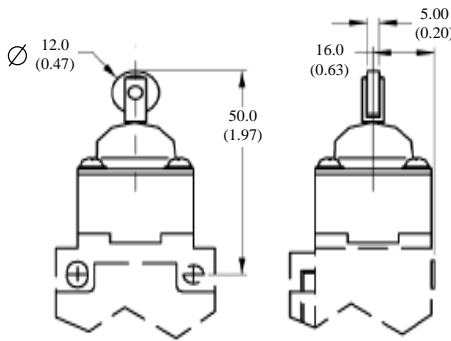

Top Push, Roller Plunger

Model No.: **PLS-1-TRP**

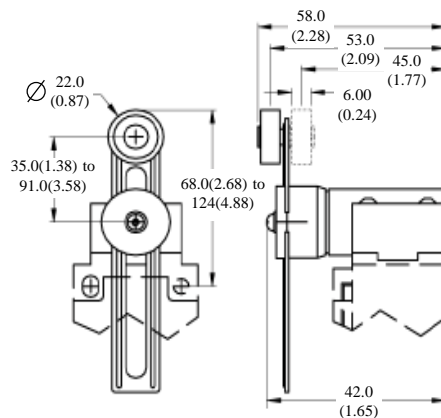

Side Rotary, Adjustable Roller Lever

Model No.: **PLS-1-SARL**

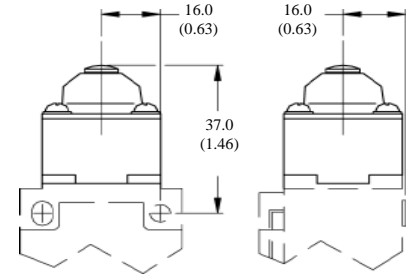

Top Push, Metal Plunger

Model No.: **PLS-1-TMP**

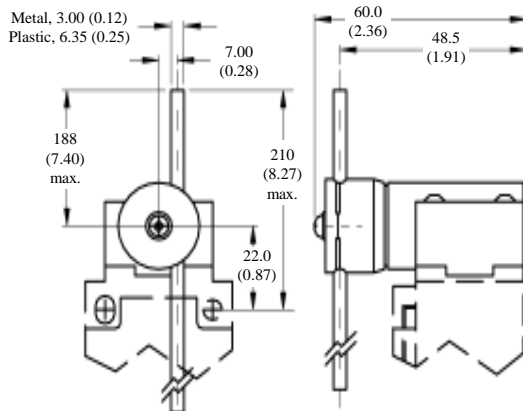

Side Rotary, Metal Rod, PLS-1-SR-MR

(Two Models)

Side Rotary, Plastic Rod, PLS-1-SR-PR

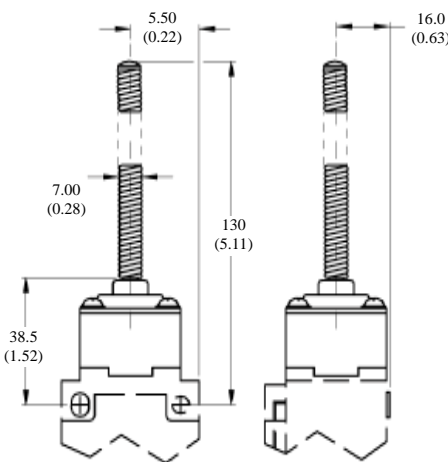

Top Wobble, Coil Spring

Model No.: **PLS-1-TCS**

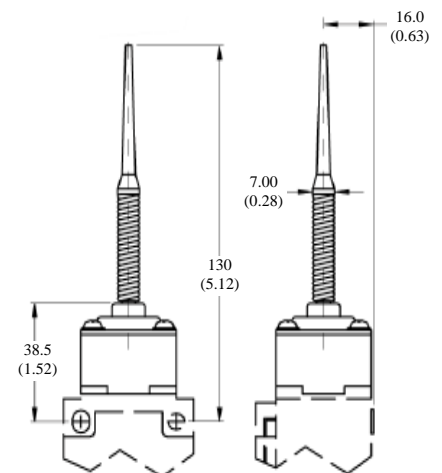

Top Wobble, Coil Spring with Poly Tip

Model No.: **PLS-1-TCSPT**

Limit Switch Mounts

For easier setup and future adjustments Install limit switch style devices using these helpful brackets. It's easier to adjust your switch with these brackets instead of modifying your equipment.

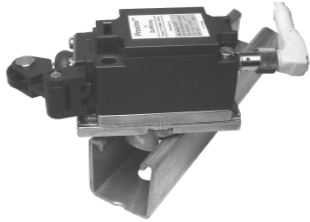
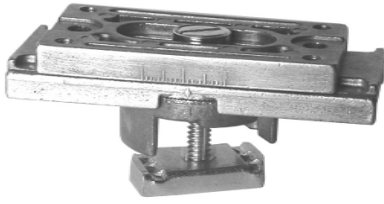

Features

- Flexible aiming for most limit switch style devices
- One and two axis adjustment types
- Secure mounting

Benefits

- Allows faster installation and setup
- Accommodate unpredictable/changing target travel
- Change switch position without equipment changes

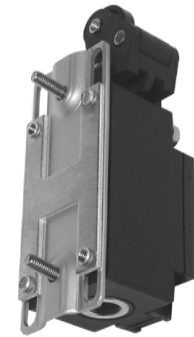

Model No.

LSM-2000

Unistrut® (1-5/8") mounting with two-way adjustment for limit switch style devices. Rotational adjustments must be completed prior to attaching switch. After which, two screws secure and allow for linear adjustments.

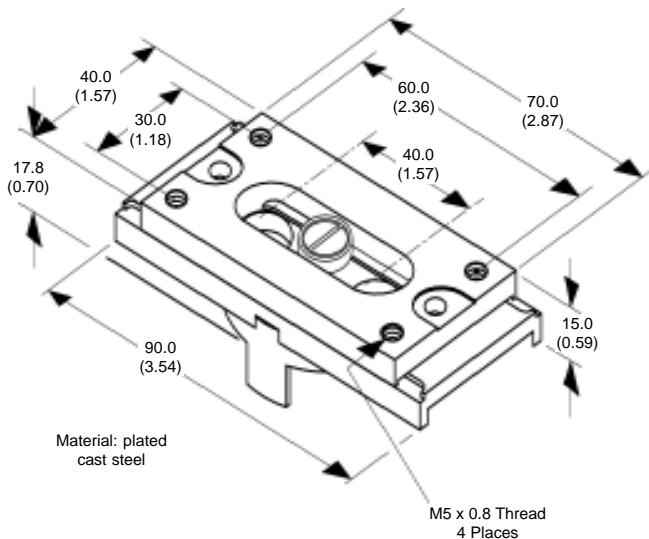
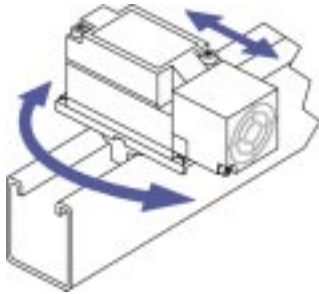

LSM-1000 One-way adjustment type. Fasteners secure bracket to equipment and then two screws allow adjustment, as well as securing switch after the correct position is located.

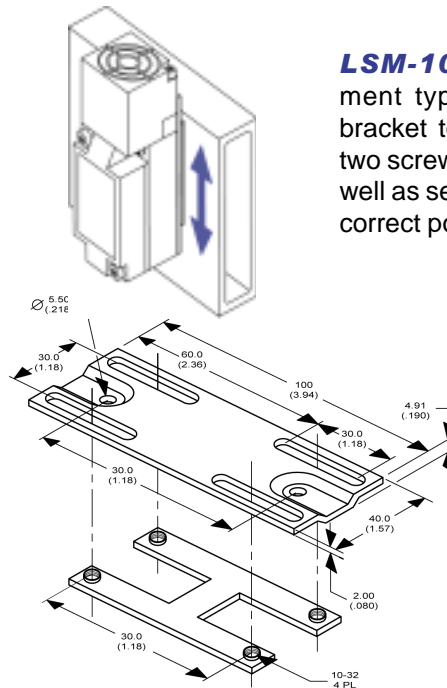

Model No.

LSM-1000

1) Dimensions mm(inch).
2) Material is aluminum with no finish. 3) Includes required fasteners for securing PLS-1 type switches; two (2) fasteners for limit switch attachment and two (2) 10-32x1/2" fasteners to secure the LSM to your equipment.

Model No.

LSM-1000M

1) Material: aluminum with no finish. 2) Includes required fasteners for securing all PLS-M type limit switches; two fasteners for limit switch attachment to mount and two M4-0.8 x 8mm fasteners to secure LSM to equipment.

LSM-1000M One-way adjustment for PLS-M limit switches and other sensors.

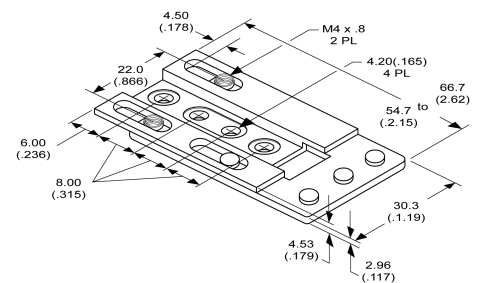

Clamp-style Universal Bracket™ (CUB)

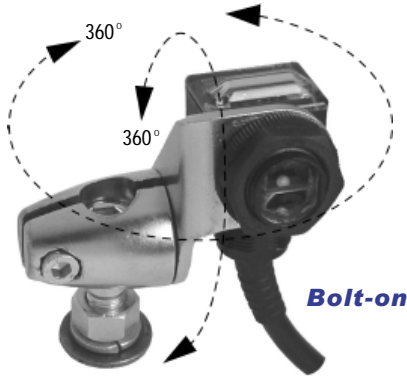

Clamp-style Universal Brackets CUB™ solutions are unmatched for their ability to position and aim photoelectric and ultrasonic sensors, offering superior rigidity for long term sensor accuracy and reliability.

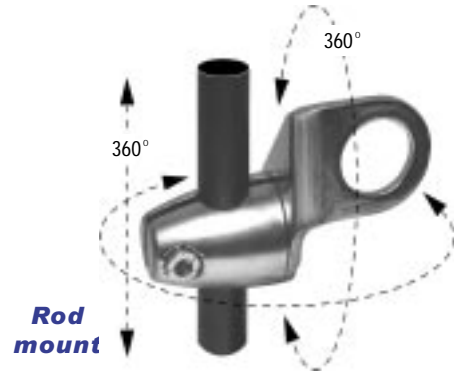

How it works- Two metal HalfKlamps attach and capture a Base, while they also secure a Bracket option to hold your sensor. Opposite the Bracket is a single adjustment fastener that is tightened to secure both the Bracket and HalfKlamp positions. The SoftNoze CUB™ puts you in ultimate control to position and securely lock sensors in place. A comprehensive selection of Base units and Brackets options allow you to harness the power of virtually any sensor and application!

Features

- Complete 360° rotation in 2 planes
- One fastener fully locks position
- Five different Base unit styles
- Wide variety of sensor Brackets

Benefits

- Ultimate aiming versatility
- Superior rigidity
- Bracket solutions for every sensor
- Rapid adjustment makes setup a snap

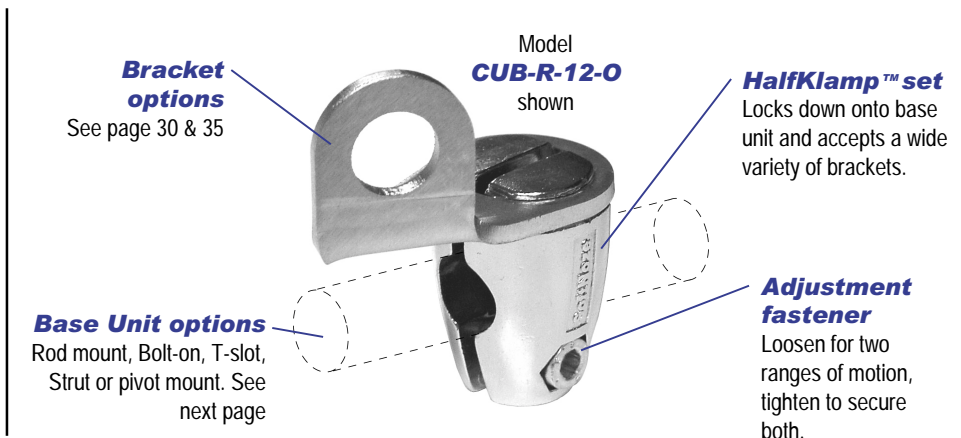

Order by Model Number- Select the exact sensor mounting configuration you need, over 50 different bracket combinations possible. Choose from the individual components on the following pages. Or order a complete kit using this model number guide:

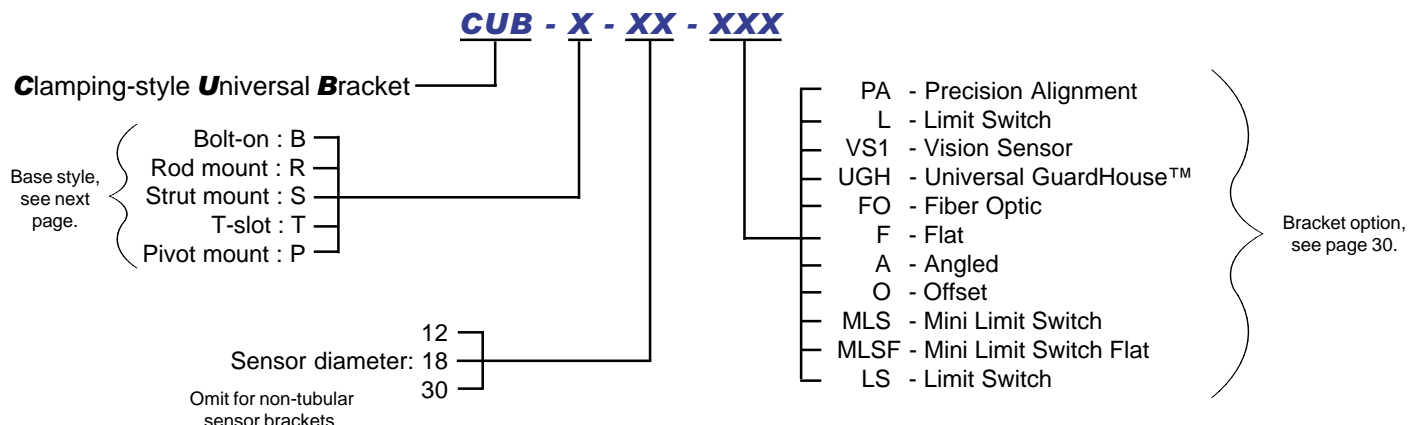

Clamp-style Universal Bracket™ (CUB)

CUB™ Base Mounting Options (Shown with optional brackets):

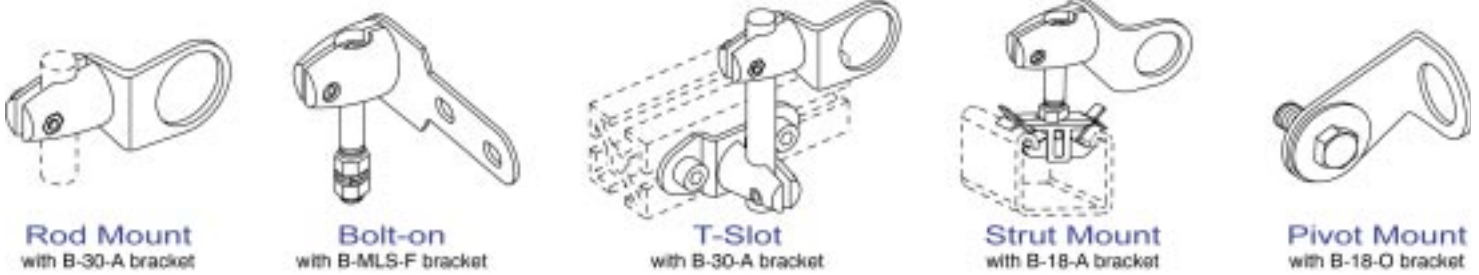

Base Mounting Option specifications- Dimensions are mm(in), select sensor brackets from next page.

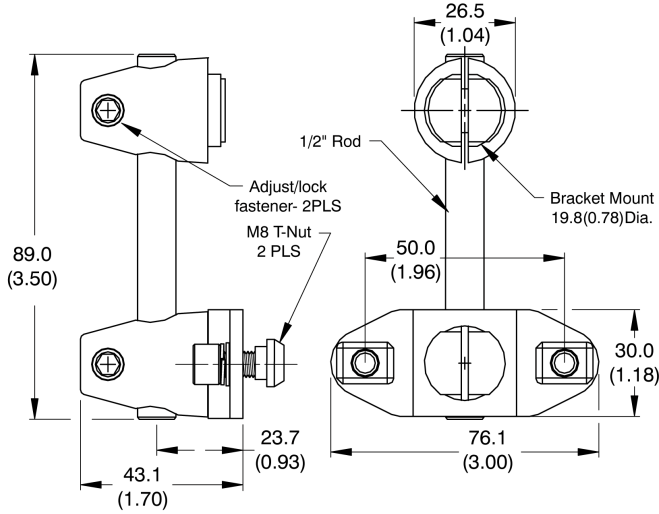

CUB-R...
Rod mount CUB™
 Half-klamp set attaches to customer supplied 1/2" diameter rod stock, or see page 33 to purchase rods from SoftNoze. Notes: 1) Materials; HalfKlamps- zinc alloy, nickel-plated, adjust/lock fasteners 303 SS.

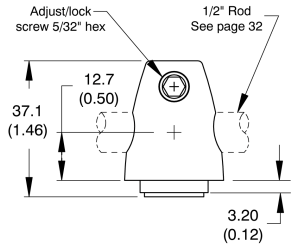

CUB-T...
T-slot mount CUB™
 T-slot bracket, two HalfKlamp sets and rod assembly attaches to most brands of extruded aluminum (T-slot). Notes: 1) Materials; HalfKlamps- nickel-plated zinc alloy, Adjust/lock fasteners- 303 SS, Bracket and Rod- stainless steel.

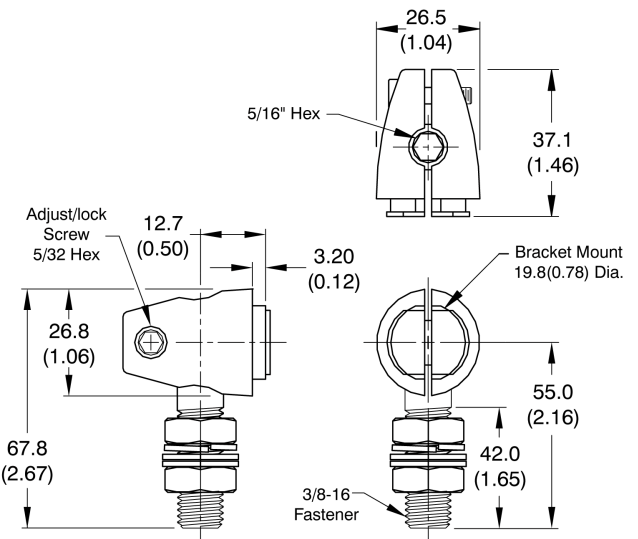

CUB-B...
Bolt-on CUB™
 Half-klamp set and 3/8 bolt attaches to through hole or a 3/8-16NC tapped hole. Notes: 1) Materials; HalfKlamps- zinc alloy, nickel-plated, fasteners- 303 stainless steel.

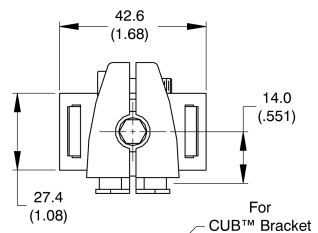

CUB-S...
Strut-mount CUB™
 Half-klamp set, 3/8" bolt and strut clip attach to customer supplied 1-5/8" wide strut channels. Notes: 1) Materials; HalfKlamps nickel-plate zinc alloy, strut clip- plated CRS other fasteners 303 Stainless steel.

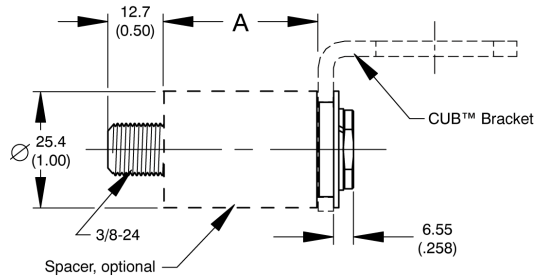
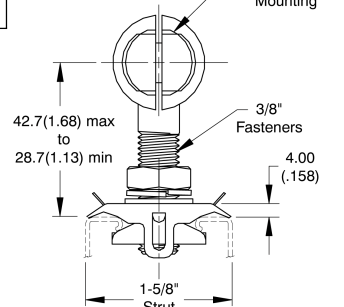

CUB-P		
Model	A	Pivot-mount CUB™
CUB-P...	0.00 (0.00)	Uses no HalfKlamp set, thus provides only a single pivoting axis. CUB brackets mount with a 3/8" low-head bolt and bushing. Optional spacers, see pg. 33. Notes: 1) Materials: Bushing, zinc-plated CRS, bolt and fasteners; all stainless steel.
CUB-P38...	38.1 (1.50)	
CUB-P76...	76.2 (3.00)	

Clamp-style Universal Bracket™ (CUB)

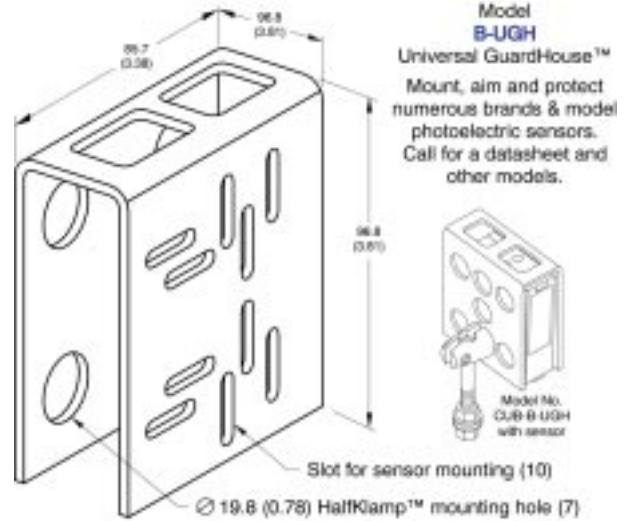
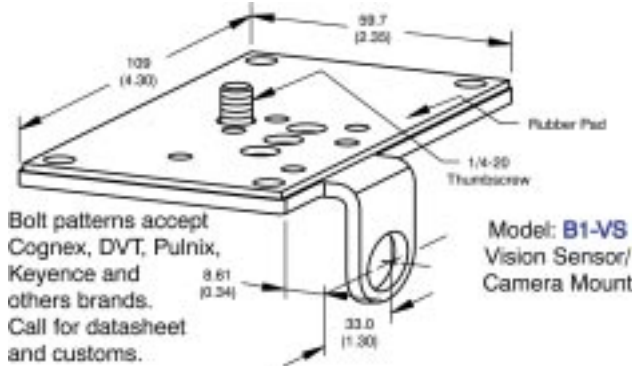
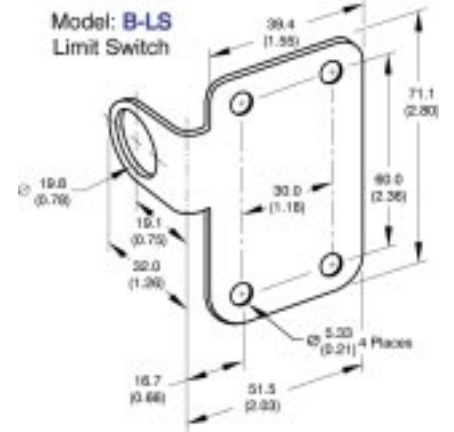
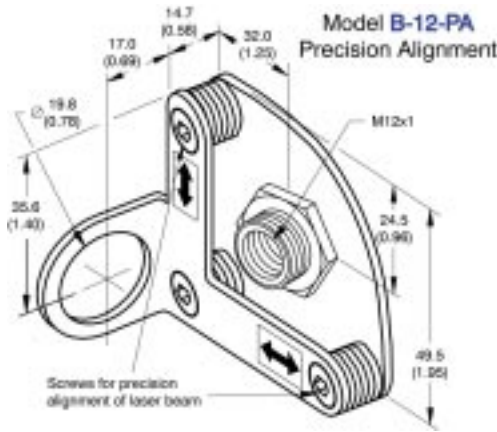
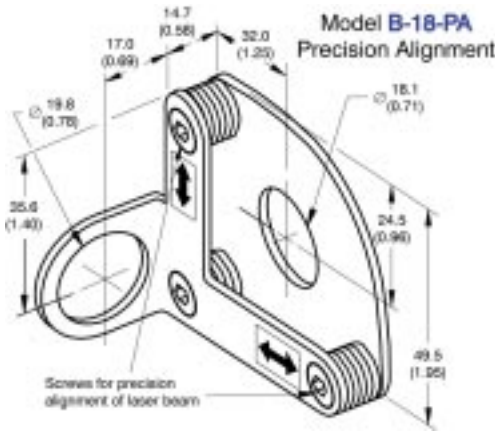

Style	Model	A	B	C	D
OFFSET	B-12-O	12.1 (0.48)	17.3 (0.68)	16.0 (0.63)	23.9 (0.94)
	B-18-O	18.3 (0.72)	19.8 (0.78)	19.1 (0.75)	31.8 (1.25)
	B-30-O	30.1 (1.19)	25.4 (1.00)	22.3 (0.88)	44.5 (1.75)
ANGLED	B-12-A	12.1 (0.48)		16.0 (0.63)	N/A
	B-18-A	18.3 (0.72)	18.5 (0.73)	20.0 (0.79)	
	B-30-A	30.1 (1.19)		28.0 (1.10)	
FLAT	B-12-F	12.1 (0.48)	54.5 (2.14)	31.1 (1.22)	N/A
	B-18-F	18.3 (0.72)	59.4 (2.34)	13.1 (33.2)	
	B-30-F	30.1 (1.19)	73.1 (2.88)	44.4 (1.75)	
Notes	1) All brackets attached to Half-Klamps via the 19.8(0.78) diameter hole. 2) Material: 304 stainless steel 3) Call for custom requirements.				

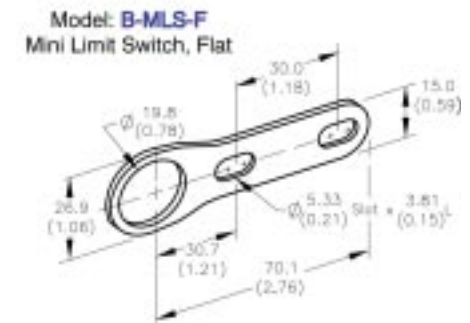
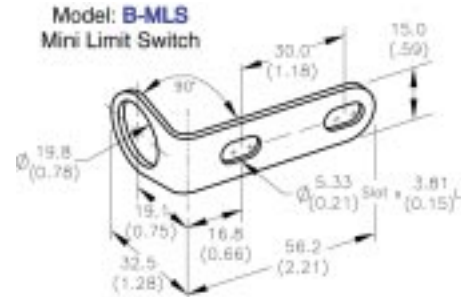
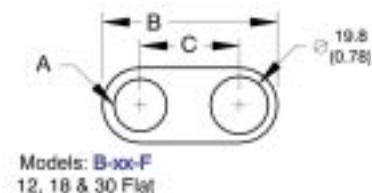
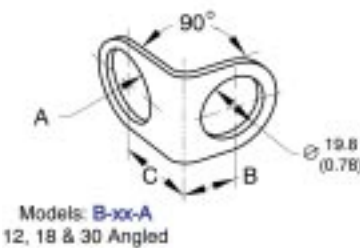
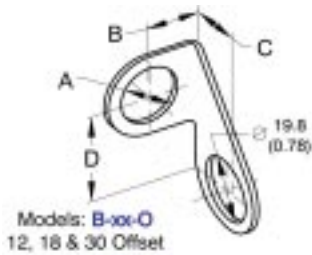

Sensor Mounting System™ (SMS)

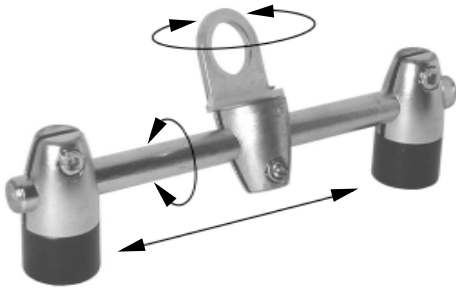

The ultimate in sensor positioning flexibility the SMS system creates a superior structure to which virtually any sensor, or multiple sensors, can be mounted and aimed. Slash labor costs and fabrication time while you achieve unmatched rigidity and versatility. Virtually any sensor can be mounted in any configuration required. When things change, all components are usable as well.

SMS™ for an 18mm tubular sensor (not shown) offering complete 360° rotation in two planes, plus a linear rail on which to slide.



Two-axis SMS™ shown securing a laser sensor.

Features

- Complete building system
- Brackets to accommodate all sensors
- Extremely rigid mounting
- Durable all-metal construction
- Assemble and adjust sensors with one wrench

Benefits

- Reduced engineering time/costs
- Quick installation
- Ultimate sensor aiming flexibility
- Great aesthetic value
- Re-configurable & reusable

SMS™ Components

Shown below are six basic Sensor Mounting System™ components, see following pages for individual part numbers and options:

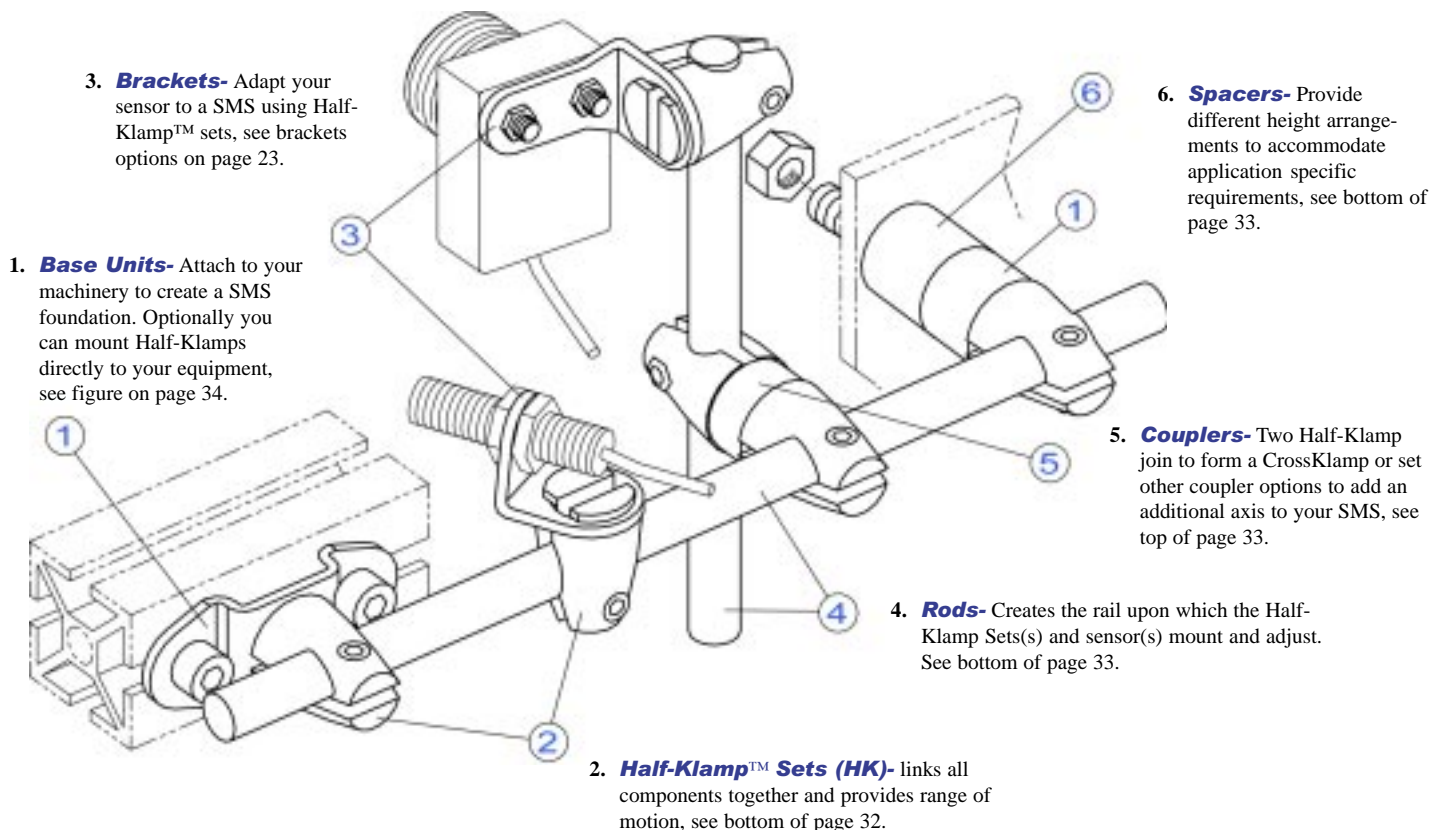

- 1. Base Units-** Attach to your machinery to create a SMS foundation. Optionally you can mount Half-Klamps directly to your equipment, see figure on page 34.
- 2. Half-Klamp™ Sets (HK)-** links all components together and provides range of motion, see bottom of page 32.
- 3. Brackets-** Adapt your sensor to a SMS using Half-Klamp™ sets, see brackets options on page 23.
- 4. Rods-** Creates the rail upon which the Half-Klamp Sets(s) and sensor(s) mount and adjust. See bottom of page 33.
- 5. Couplers-** Two Half-Klamp join to form a CrossKlamp or set other coupler options to add an additional axis to your SMS, see top of page 33.
- 6. Spacers-** Provide different height arrangements to accommodate application specific requirements, see bottom of page 33.

Sensor Mounting System™ (SMS)

Selecting a Base mounting option- Four types (No. 1-4) or five (No. 5) simply punch a hole in your machine panels:

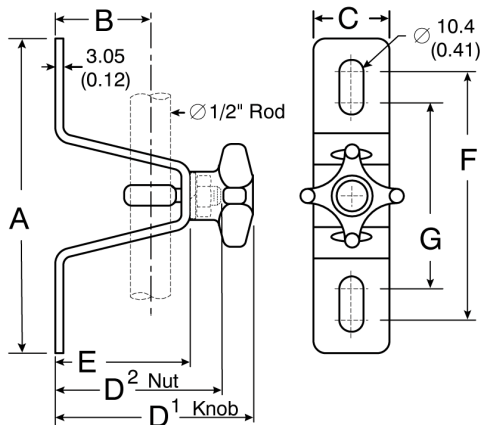
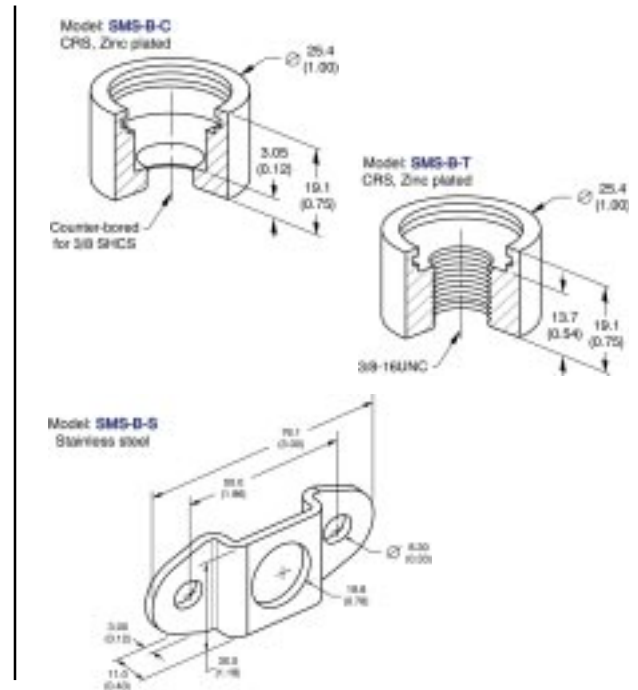
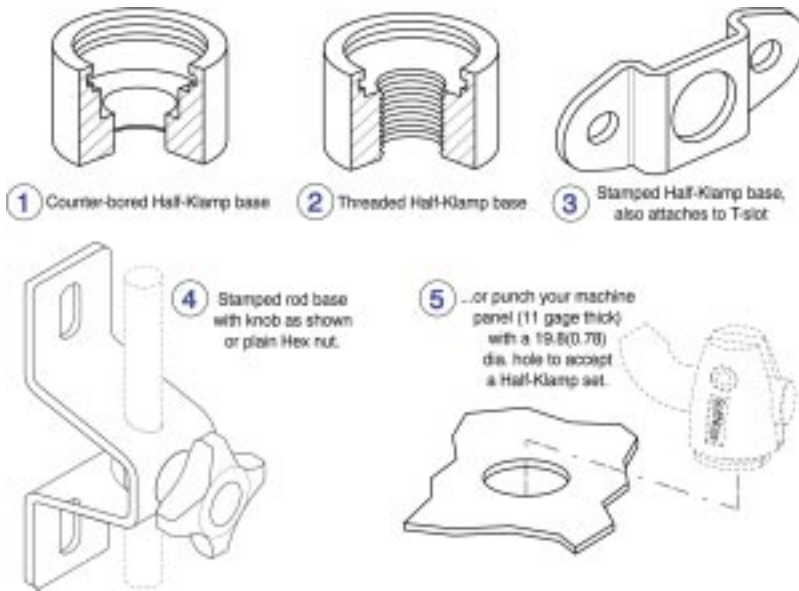

Model No.	A	B	C	D ¹	D ²	E	F	G
SMS-B-R1	102 (4.00)	23.4 (0.92)	28.6 (1.13)	N/A	49.1 (1.94)	39.6 (1.56)	76.2 (3.00)	63.5 (2.50)
SMS-B-R1K				69.9 (2.75)	N/A			
SMS-B-R2	127 (5.00)	38.8 (1.53)	31.8 (1.25)	N/A	65.5 (2.58)	55.9 (2.20)	102 (4.00)	76.2 (3.00)
SMS-B-R2K				86.1 (3.39)	N/A			
Notes	A stainless steel bracket and eyelet secure 1/2" diameter rods. R1 and R2 models have nut only. R1K and R2K have plastic (polyamide) knob for rapid sensor position adjustments.							

Half-Klumps- Use to secure 1/2" diameter rods to Base units, the attachment of sensors and to link other SMS components together. Two different options include; the HK model that adjusts with a allen wrench, or select the tool-less adjustment option HK-H with handled:

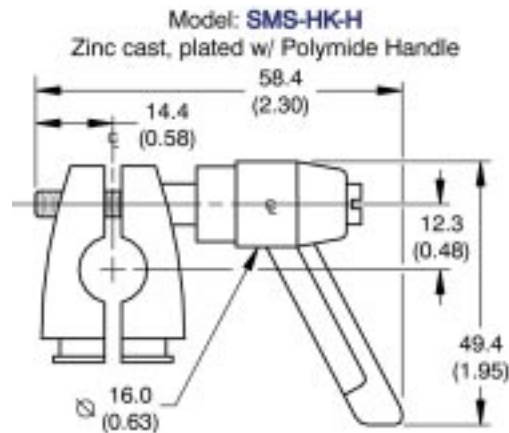
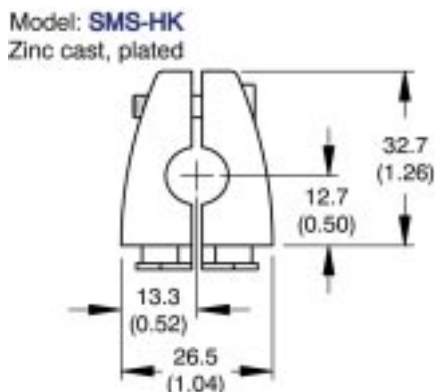

Sensor Mounting System™ (SMS)

Coupling options- Order a Coupler element separately or together with two Half-Klamps, which form the required "crossblock" for a two-axis system. Also available are two economy CrossKlamp™ couplers:

Model: **SMS-C**
CRS, Zinc plated

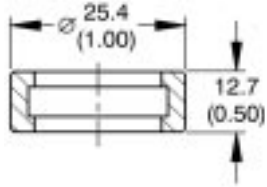

Coupler

Model: **SMS-CK**
CRS, Zinc plated

Replace "CK" with "CKH" in above model number for a crossblock with handles, see page 32 for handle dimensions.

CrossKlamp™

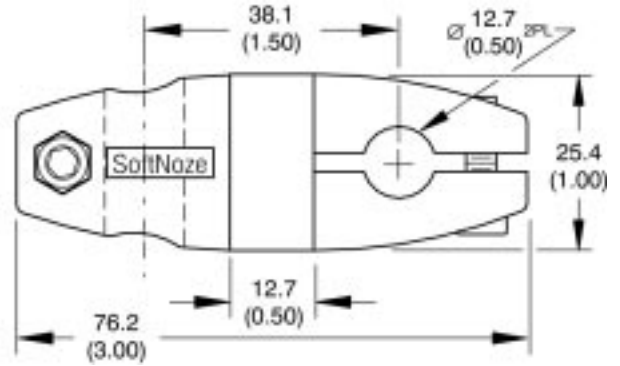

Model: **SMS-CC**
Stainless steel

CrossCoupler™

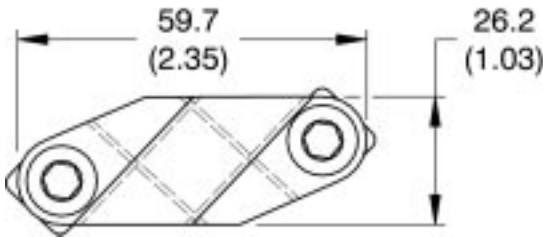

The SMS-CC model coupler will hold two 1/2" SMS rods at a fixed 90 degree angle.

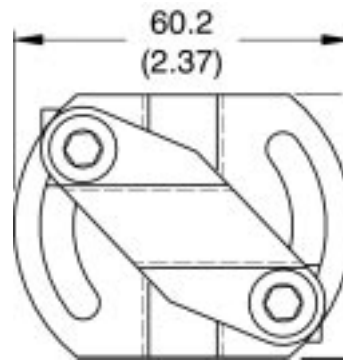

Rotating CrossCoupler™

Model: **SMS-CCR**
Stainless steel

The SMS-CCR rotating coupler will hold two 1/2" SMS rods at a 90 degrees, adjustable to +/- 22 degrees.

Rods- Order Rods to form the required sensor adjustment rails and support structures:

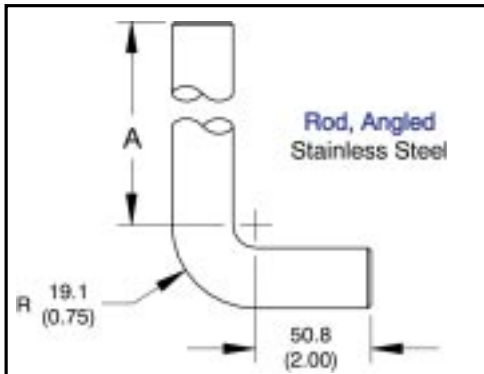

Rod, Angled
Stainless Steel

Model	A	Model	A
SMS-RA-50	50 (1.97)	SMS-RA-200	200 (7.87)
SMS-RA-75	75 (2.95)	SMS-RA-300	300 (11.8)
SMS-RA-100	100 (3.94)	SMS-RA-450	450 (17.7)
Notes	Diameter is 12.7(0.50), material is 303 stainless steel. Custom lengths and configurations quoted upon request.		

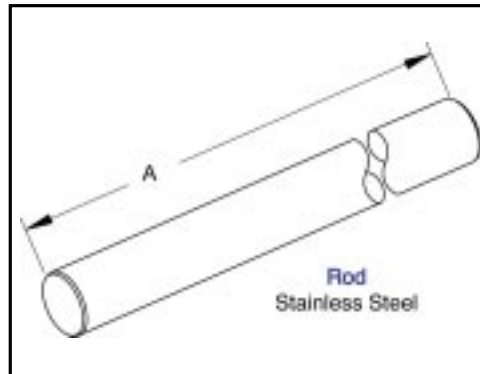

Rod
Stainless Steel

Model	A	Model	A
SMS-R-100	100 (3.94)	SMS-R-450	450 (17.7)
SMS-R-150	150 (5.91)	SMS-R-600	600 (23.6)
SMS-R-300	300 (11.8)	SMS-R-750	750 (29.5)
Notes	Diameter is 12.7(0.50), material is 303 stainless steel. Custom lengths and configurations quoted upon request.		

Spacers-Height adjusters:

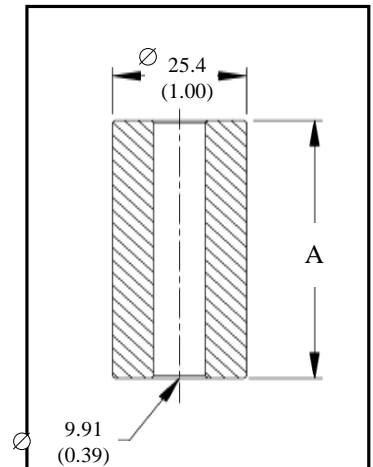

Model	A
SMS-S-38	38.1 (1.50)
SMS-S-76	76.2 (3.00)

Sensor Mounting System™ (SMS)

SMS Universal Kits- Order a complete SMS solution with a single part number. For example, shown below is model number SMSUK-B18A-RA50-HK:

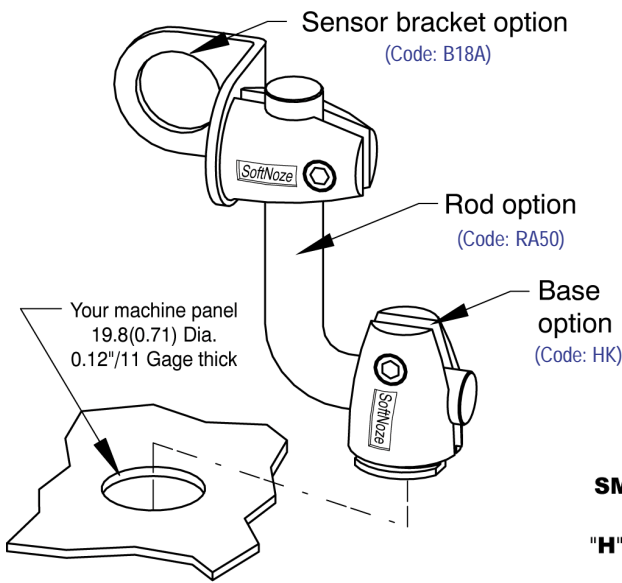

Sensor Mounting System Universal Kits

Building your model- Start with the prefix SMSUK, then add a sensor Bracket code, a Rod code and finally the code for a base option. If you want handles on either of the Half Klamps, add an "H" after the Bracket and or Base codes, for example the above part number would become SMSUK-B18AH-RA50-HKH. Here are more examples of SMSUK model numbers:

- Bracket code BVSH, Vision System Bracket w/ handle, see pg. 30
- Rod code R750, 750mm long Rod, straight style, see pg. 33
- Base codes BTH, Threaded Base with handle, see pg. 32
BR2K, Rod style base bracket, see pg. 32

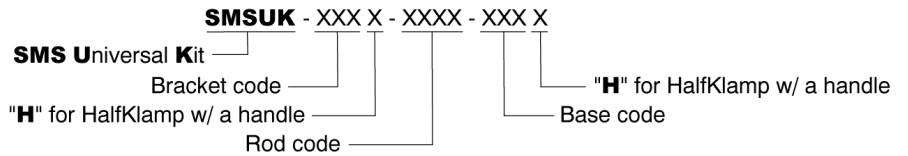

Universal Conveyor Bracket™ (UCB)

Select from three standard models. Each ships complete with a base post assembly, coupler, sensor post and sensor bracket. Model numbers shown here are the; UCB-B1-200-C1-300-PB1, UCB-B1-200-C1-300-PB2 and UCB-B1-200-C1-300-PB2G.

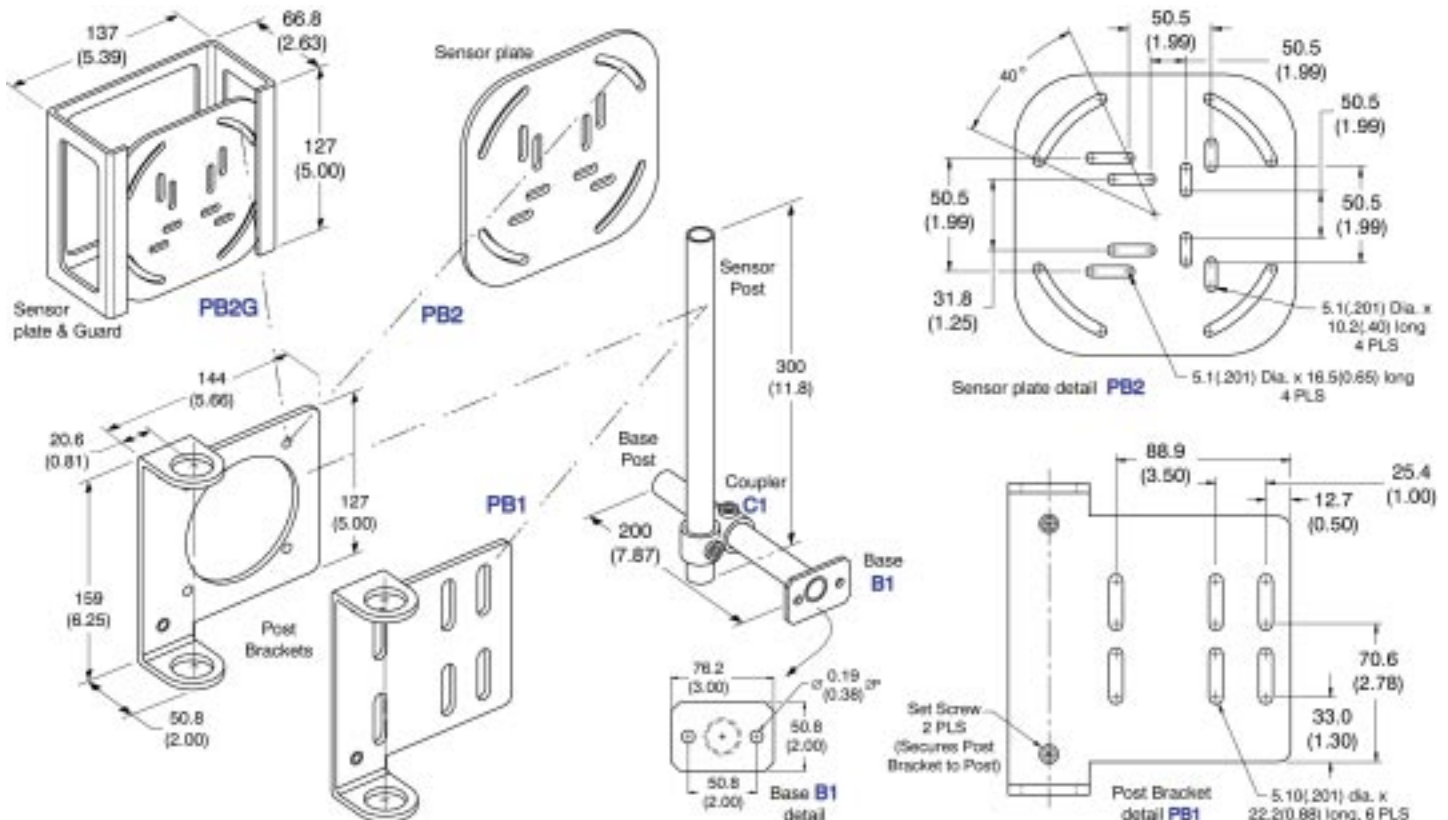

Swivel-style Universal Brackets (SUB)

Swivel-style Universal Bracket Attach threaded barrel photoelectric and ultrasonic sensors, mini photoelectrics, as well as limit switch-style devices having M30 threaded bases. Achieve easy aiming and secure mounting with these durable, glass-filled nylon brackets.



Features

- Durable Glass-filled Nylon Construction
- Regular or Extended Base Models
- Sizes for 12, 18 and 30mm Threaded Sensors
- Blank for mounting mini photoelectrics
- T-Slot mounting fastener option

Benefits

- Easy Sensor Installation and Setup
- Corrosion-Resistant
- Stock Mounting Solutions
- Direct attachment to T-Slot



SUB-30 with M30 x 1.5 threaded barrel ultrasonic sensor.



SUB-30 with photoelectric having a M30 x 1.5 threaded base.



User-drilled, SUB-MPB shown with mini photoelectric sensor.



SUB-30-TS, supplied with all fasteners for T-Slot mounting.

Model No.	Thread
SUB-12	M12 X 1
SUB-18	M18 X 1
SUB-30	M30 X1.5
SUB-MPB	User drilled & tapped, or use double-backed adhesive tape.
Notes	<p>1) Order by model number. 2) For extended base option, use SUBE in the model number, for example SUBE-30. 3) For included T-Slot fasteners, add "TS" to the end of the model number, for example SUBE-30-TS. 4) T-Slot option fasteners adapt SUB's to most 30mm size and up extruded aluminum profiles. 5) Housing material is glass-filled Nylon and fasteners are stainless steel. 6) User provides sensor fasteners on MPB versions. 7) MPB blank is black Delrin®.</p>

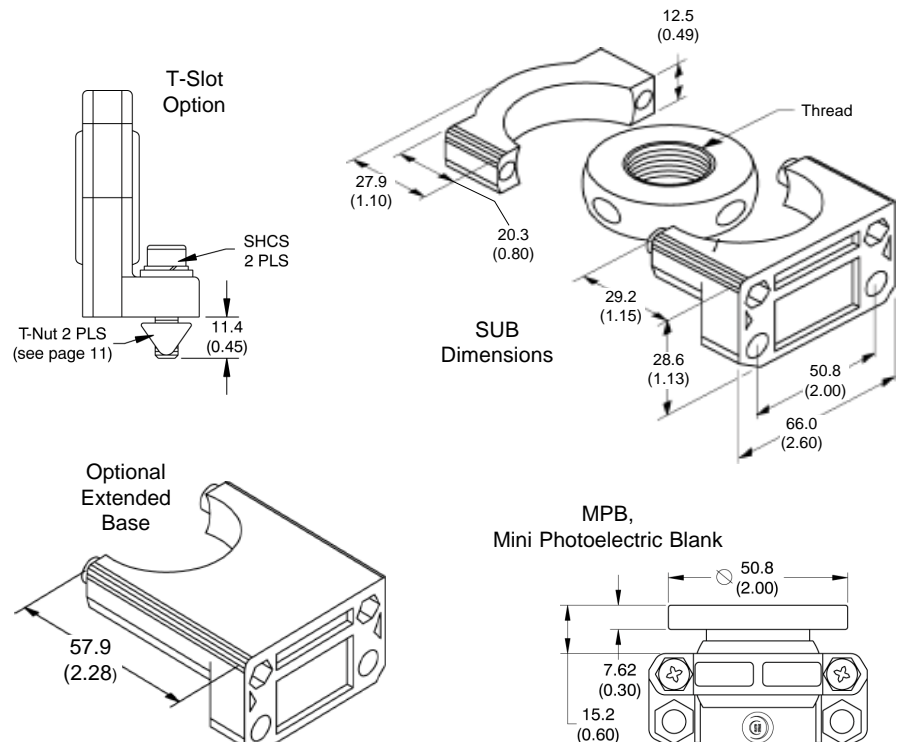

Articulating-style Universal Brackets

Articulating-style Universal Bracket

Aiming is important when setting up ultrasonic and photoelectric sensors. These brackets provide secure mounting and flexible aiming in one or two directions. Call factory when applications and/or sensors require a different configuration, SoftNoze makes customs!

Features

- Rugged Steel Construction
- 1 or 2 Axis of Adjustment
- Accepts Additional Brackets

Benefits

- Easy Installation and Setup
- Secure Mounting
- Save Money/Use a Stock Mount



Secure mounting and flexible aiming for block-style ultrasonic sensors, as well as numerous types of sensors and switches (AUB-200 shown).

Note: attach a bracket from pages 10, 14 or 15 to the AUB-type mounts to also accommodate tubular sensors.

Specifications: Bolt pattern shown at right is for sensor mounting. The footprint of each AUB bracket provides four 7mm diameter clearance holes (not shown at right) for mounting the AUB, these 7mm holes are 65mm apart like the tapped M5(4PL).

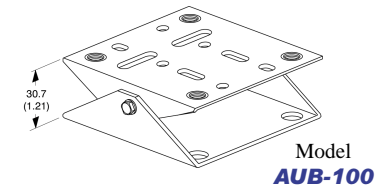
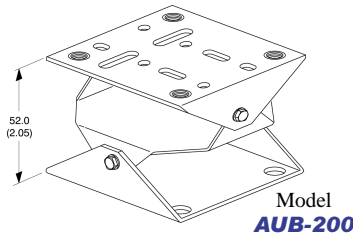
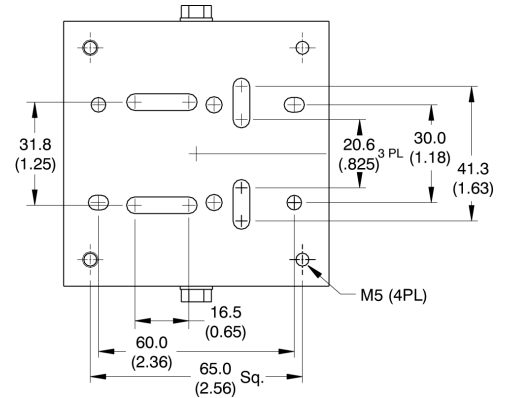

Fiber-optic Mounting System™

Use the components below along with our CUB and SMS components (pages 28 to 33) to position and secure fiber optic cables as shown at the right, as well as into other configurations. Customs components are available.

Fiber-optic bracket for CUB™ mounting

Model Number:
FMS-CUB

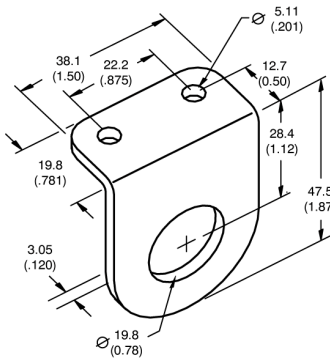

Model FO-CUB ships complete with all required fasteners to attach a Fiber Optic Base unit (all stainless steel):

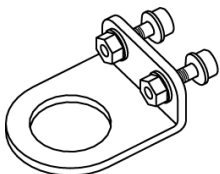

Fiber-optic Base

Model Number:
FMS-B1-38-125
Anodized Aluminum

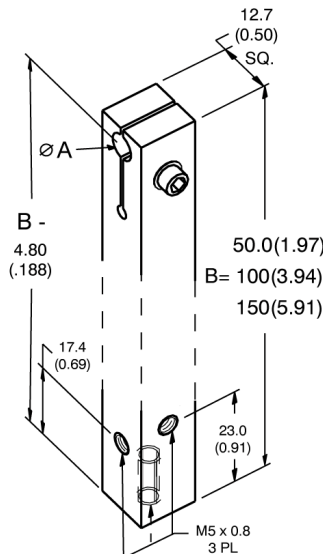
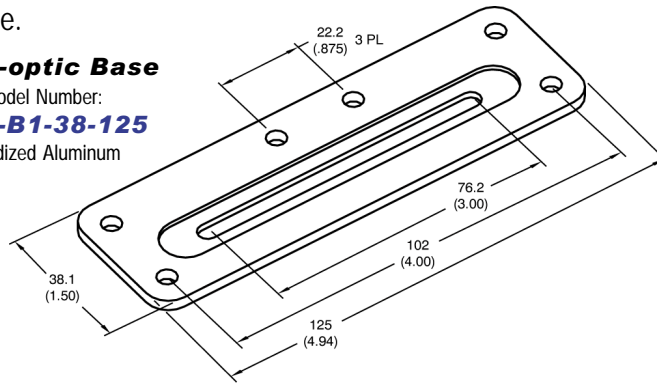

Fiber-optic Post See model number tree and call factory to mount different diameter fibers and other customizations.

Here are a few mounting ideas:

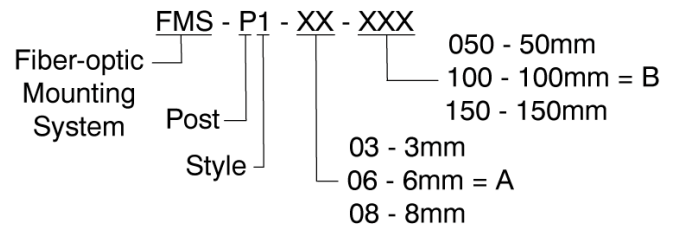
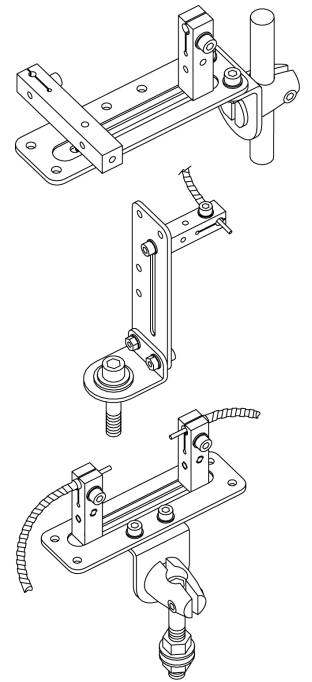

Reflectors & Reflector Brackets

With or without protective and highly adjustable aiming brackets Or just purchase a bracket for your reflector. Two diameters, 44 or 88mm and 8 different reflector/bracket combinations:

Bracket Only

Bolt-on
CUBR-B-88
CUBR-B-44

Rod Mount
CUBR-R-88
CUBR-R-44

Reflector & Bracket

Bolt-on
CUBR-B-R1-88
CUBR-B-R1-44

Rod Mount
CUBR-R-R1-88
CUBR-R-R1-44

Reflector Only

Models	A
... 88	88.9 (3.50)
... 44	44.5 (1.75)

Model	A	B
R1-84	84.0 (3.30)	7.62 (0.30)
R1-42	42.0 (1.65)	N/A (self-adhesive)

See page 31 for additional bracket dimensions

Square-style Reflectors/Brackets



Order with or without a protective aiming bracket. Our stock solutions insure your photoelectrics get the signals they need. We have versatile stock solutions as well as custom capabilities. Let SoftNoze stock and ship your components as you need them.

Features

- Stainless Steel Construction
- Fixed or Easy Alignment
- With or without reflectors

Benefits

- Save Money- use a Stock Bracket
- Protected Mounting for Reflectors
- Faster time to market

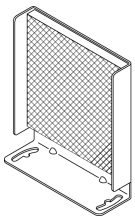

With Reflector

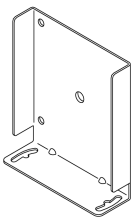

Without Reflector

Model*	A	B	C	D	E	Dia.
RBGH-1-xxx	68.0 (2.68)	62.0 (2.44)	36.0 (1.42)	26.0 (1.02)	25.4 (1.00)	4.50 (0.18)
RBGH-2-xxx	92 (3.62)	95 (3.74)	56.0 (2.20)	46.0 (1.81)	30.0 (1.18)	4.50 (0.18)
RBGH-3-xxx	107 (4.21)	110 (4.33)	66.0 (2.60)	56.0 (2.20)	38.1 (1.50)	6.35 (0.25)

*Please request our data sheet for models "RBGH" for complete specifications and ordering information. Ordering options for direct T-slot and Unistrut® mounting available.

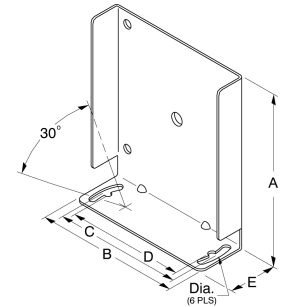

Photoelectric & Reflector Conveyor Bracket Pairs

Order individually or in pairs SoftNoze can help equip conveyor systems with useful control accessories. We can also add legend plates so you can identify sensor/input numbers. Too many features and options to show here...let SoftNoze sweat the details.

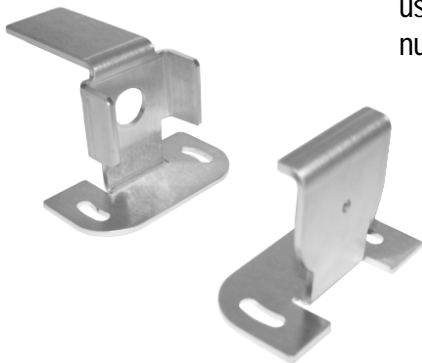

Features

- Stainless Steel or Steel/primed Construction
- For 12 and 18mm controls
- Easy Adjustment and/or Aiming
- Standard or Unistrut® Mounting

Benefits

- Protected Mounting for Reflectors/Sensors
- Save Money- use a Stock Bracket
- Secure & Protected Mounting
- Industry Standard Solutions

Request our data sheet for models "PBGHIRBGH"

Photoelectric Bracket-GuardHouse & Reflectors Bracket-GuardHouse

Snake Mount™

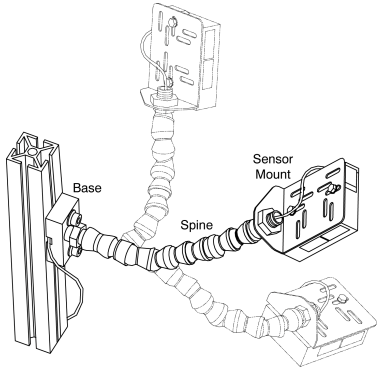

Extreme aiming and repositioning flexible for assembly, packaging and bottling line photoelectrics!

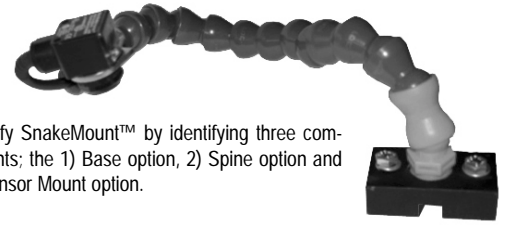

Specify SnakeMount™ by identifying three components; the 1) Base option, 2) Spine option and 3) Sensor Mount option.

The SnakeMount™ by SoftNoze offers a flexible snake-like spine for attaching and aiming popular photoelectric sensors. With the SnakeMount you simply bend, push and pull the flexible spine to align your photoelectrics. No tools are needed and repeated reconfigurations for changing products runs are both quick and easy.

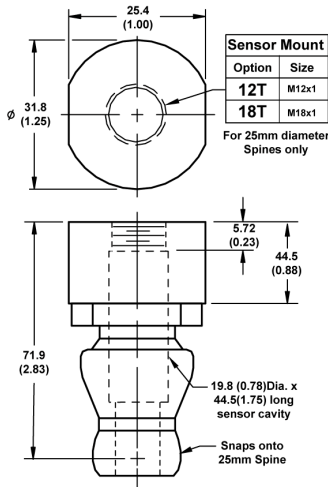
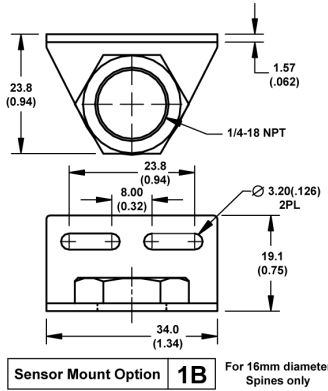
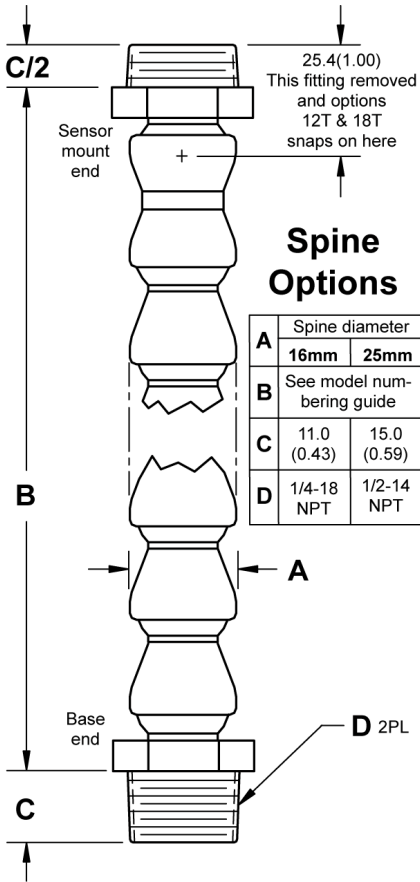

Sensor Mount Options- select from four options; two metal brackets (1B & 2B) for miniature and rectangular sensors or two plastic adapters for tubular sensors (12T & 18T). Custom mounts are readily quoted.

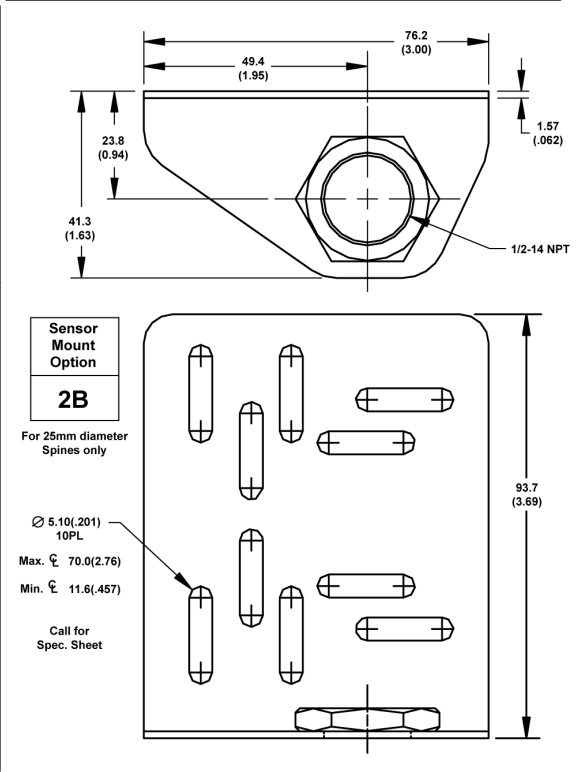

SM - X - XX - XXX - XXX

SnakeMount

Base option

0 - No base option

1 - Bolt-on base

2 - CUB™ base

Sensor Mount Option

1B - Bracket for 16mm spine

2B - Bracket for 25mm spine

12T - M12x1 adapter for 25mm spine

18T - M18x1 adapter for 25mm spine

Spine dia. (A)

Spine length (B)

16mm - 16	111mm - 111
	185mm - 185
25mm - 25	190mm - 190
	330mm - 330

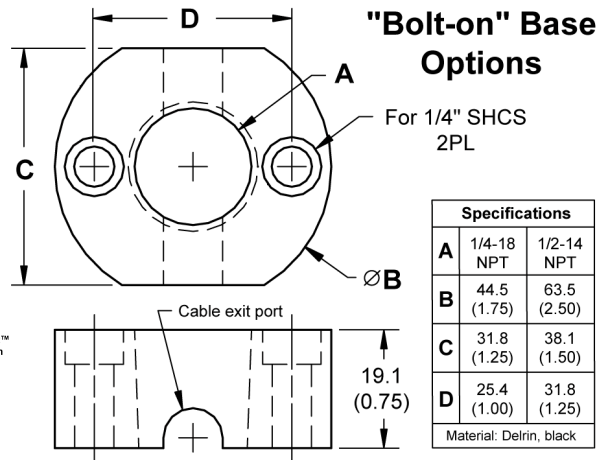
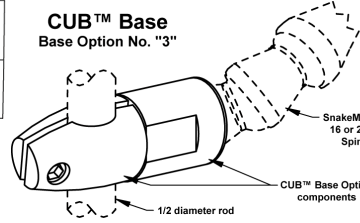

Sensor Wells

Sensor Wells are used to adapt tubular proximity sensors to a wide variety of vessels for level detection applications. Different style wells allow a variety of attachment options. Sensor Wells keep systems sealed prior to sensor installation, as well as during sensor removal. Reliability and performance is improved because the sensor is isolated from the system fluid(s) or material(s).

Features

- Delrin®, HDPE and Teflon® models
- Accommodates all sensor diameters
- Six types including Flange Mount, SAE & NPT threads
- Casted welding flange accessories

Typical Application

At right is a partial tank cross-section with a Weld Flange (see pg. 11) welded through the tank wall. It holds our SAE type Sensor Well. This assembly reliably seals the tank (with or without the sensor) and isolates the sensor from the tank's contents.

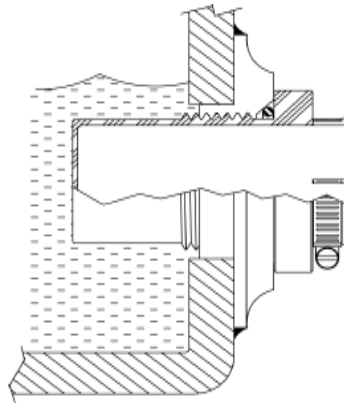

Benefits

- Isolates sensor from system fluids / materials
- Highly reliable sealing method
- Simplifies sensor changeout process
- Extends the sensor operating lifetime

Types of Sensor Wells

Type	Description	Attachment
FM	Flange Mount	Bolts on via 4-bolt flange
PT	NPT Thread	Threads into pipe couplings
SAE	SAE Thread	SAE thread with O-ring
BH	BulkHead	Through hole mounting
CT	Conduit Type	Threads into conduit or pipe
WO	Weld-On	Welds onto plastic tanks

(Plus any customs upon request)

Flange Mount Models

Specifications

Model No.	A
SW-FMSB-30	30.1(1.19)
SW-FMSB-32	32.1(1.26)
SW-FMSB-34	34.1(1.35)

Notes- Flange Mount Smooth Bore (FMSB) models are fabricated using UHMW polyethylene. The O-ring, with an OD of 88.0(3.46), produces the seal and is supplied with Sensor Well.

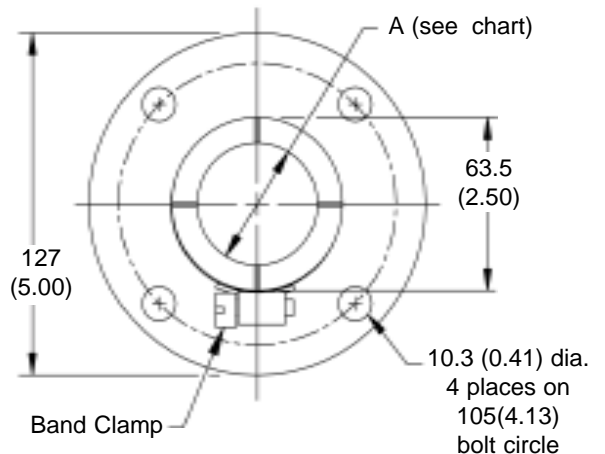
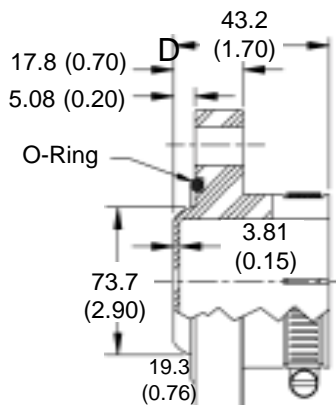

Sensor Wells

SW-PTSB model sensor wells are fabricated from either Delrin® or Teflon®. Specify material type by adding a “D” or “T” suffix to model number, for example “SW-PTSB-12-D”. Weld flanges to aid the installation of these wells are available, see page 18.

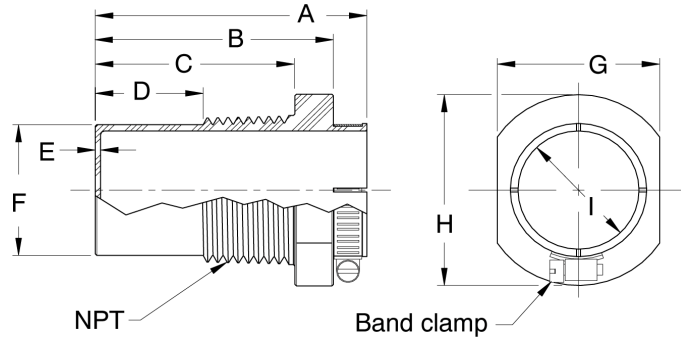

Model	A	B	C	D	E	F	NPT	G	H	I
SW-PTSB-12	44.5 (1.75)	33.0 (1.30)	26.7 (1.05)	9.14 (0.36)	0.76 (0.03)	17.8 (0.70)	1/2 x 14	25.1 (0.99)	31.8 (1.25)	12.1 (0.48)
SW-PTSB-18	59.7 (2.35)	48.1 (1.90)	38.9 (1.53)	16.5 (0.65)	1.27 (0.05)	22.6 (0.89)	3/4 x 14	31.5 (1.24)	37.3 (1.47)	18.1 (0.71)
1.91 (0.08)					36.6 (1.44)	1-1/4 x 11.5	44.5 (1.75)	50.0 (1.97)	30.1 (1.19)	
19.3 (0.76)				2.03 (0.08)	41.1 (1.63)	1-1/2 x 11.5	56.9 (2.24)	63.2 (2.49)	32.1 (1.26)	
SW-PTSB-34										34.1 (1.34)

SW-SAESB-18-D - Fabricated from Delrin®. Call for additional sizes. See page 18 for a mating weld flange.

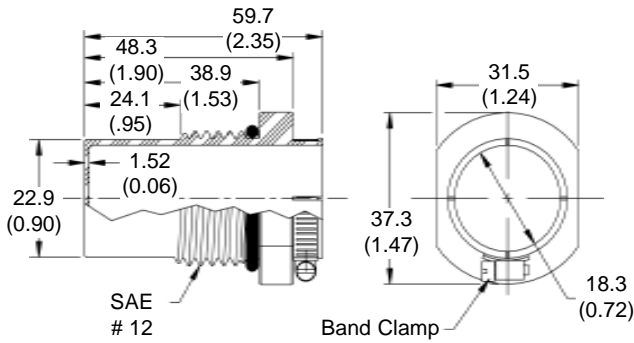

SW-CTTB-30-T - Fabricated from Teflon®. Call for additional sizes and or different materials.

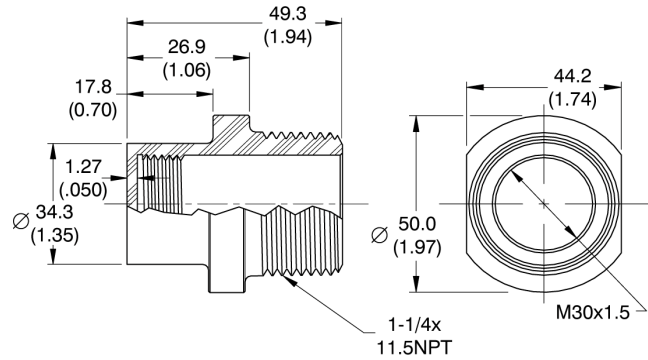

SW-BHSB-30-D - Well & nut fabricated from Delrin®. Gaskets supplied. Call for additional sizes.

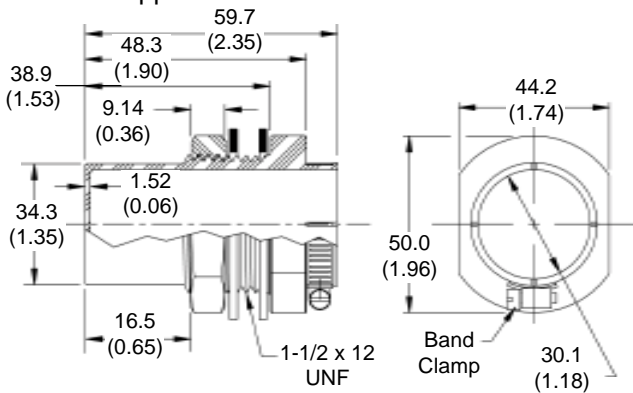

SW-WOSB-30-”XX” - Specify “PE” for polyethylene or “PP” for polypropylene. Call for datasheet for additional sizes.

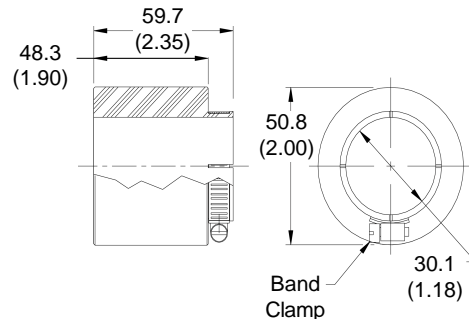

Sight Glass Mounts



Sight Glass Mounts Quickly attach tubular proximity sensors to glass and plastic tubes for level detection. Often used in pairs to detect absence or presence of liquids to activate pumps and drains in process control applications.



Features

- Adjusts "on the fly" with visual feedback
- Models for 12, 18 and 30 sensors
- For 9.5mm (3/8") to 44mm (1-3/4") pipes
- Delrin® construction with all stainless steel fasteners

Benefits

- Instantly converts tubular controls to level sensors
- Rapid, "out of tank" level adjustments
- Simple sensor change-out / replacement
- Very secure mounting

Typical Application

Shown below are two Sight Glass mounts attached to a sight tube on a large tank. Each mount holds a capacitive sensor which senses through the glass tube and monitors for the presence of the tank's contents. The bottom sensor turns the pump on and the top sensor turns the pump off. Changing activation points is accomplished simply by sliding the mounts along the sight tube.

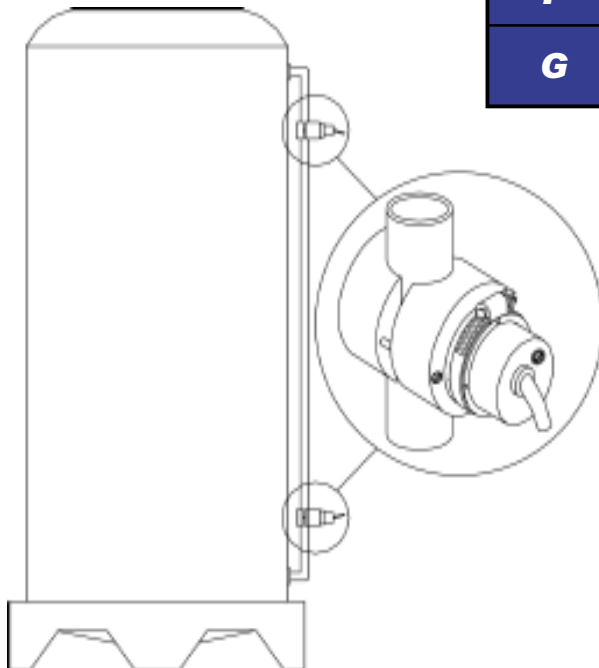

Model	SG-12	SG-18	SG-30	SG-32	SG-34
A	12.1 (0.48)	18.1 (0.71)	30.1 (1.19)	32.1 (1.26)	34.1 (1.34)
B	19.6 (0.77)	25.4 (1.00)		36.8 (1.45)	
C	38.1 (1.50)	45.0 (1.77)		69.9 (2.75)	
D	29.5 (1.16)	38.1 (1.50)		67.8 (2.69)	
E	13.0 (0.51)	15.9 (0.63)		31.8 (1.25)	
F	10.5 (0.42)	11.7 (0.46)		19.1 (0.75)	
G	9.40 to 20.6 (0.37 to 0.81)	9.40 to 20.6 (0.37 to 0.81)		25.4 to 44.5 (1.00 to 1.75)	

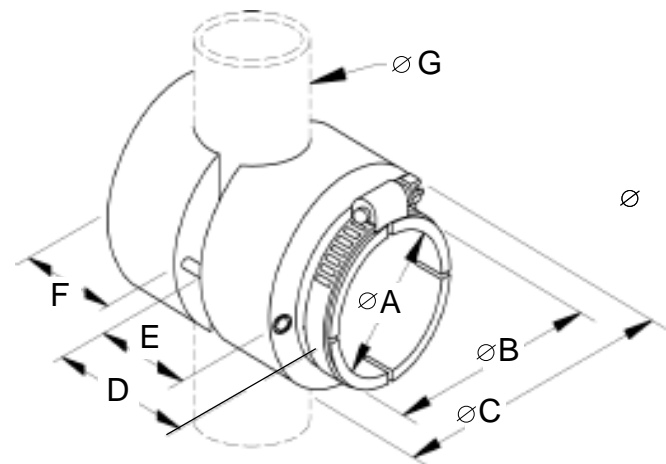

Sensor Test Set



Full-function sensor tester pocket-sized with easy push-type terminals makes wire connections quick and easy. Allow troubleshooting and or demonstration of DC sensors; 2, 3, 4-wire and NAMUR type sensor built to DIN 19234. Confirms operation of inductive, photoelectric, capacitive and ultrasonic sensors.

Features

- Wiring instructions printed on case
- Easy connect, spring-loaded, wire terminals
- Dual operation indicators LED and buzzer
- Rugged, nonmetal, case
- Uses and supplied with two 9V battery

Benefits

- Easily confirm sensors operation
- Confirm PNP vs. NPN
- Reduce troubleshooting time
- Simple tool to aid sensor setup
- Excellent sensor demonstration tool

Model Number		Wiring Connections	
TS1-DC		<p>NAMUR & 2 wire Sensors ——— Brown to + Blue to Signal</p> <p>(18 VDC)</p> <p>3 & 4 wire Sensors ——— Brown to + Blue to - (Ground) White to Signal (NC) Black to Signal (NO)</p>	
Supply Voltage	18 VDC		
Maximum rated load	100mA (fused)		
Leakage current			
Short circuit protection	Yes		
Over voltage protection	Yes		
LED display	Yes (2)		
Audible output	Yes		
Operating temperature	Room temperature		
Humidity	80% noncondensing		
Housing material	ABS		
Protection class	IP67		
Battery	9v (2)		

Custom Product Request (CPR)

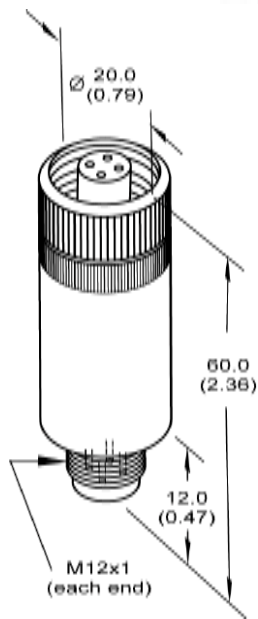

Change sensor output - No PLC programming

ProxConverter installs quickly between proximity sensors and cordsets. Easily programmed, your existing sensors can become speed monitors, timers, counters or inverters.



Features

- Single function or All-in-One models
- Standardized M12x1 connectivity
- Short circuit protection / 400mA load
- IP 67 environmental rating
- Compact size, 20x60mm

Benefits

- Control changes without PLC programming
- Reduces sensor inventories
- Eliminate expensive signal converters
- Add control functionality to basic sensors
- Remote programming via PDA

Four (4) signal function models for any 3-wire DC device (Inverter, Timer, Counter, Speed Monitor), plus a Universal, all-in-one model. Single function ProxConverters can also be combined in series to provide multiple functions, such as a speed monitor with a time delay. All versions can be used as a switching amplifier, providing output currents up to 400 mA. ProxConverters are easy to install and program compared to complex timers and counters. Effective solutions in tight spaces and where an external controller is not available/desired.

Inverter- convert a PNP (Sourcing) input signal to NPN (Sinking) or vice versa. Can also invert the function of the sensor from Normally Open to Normally Closed.

Timer- is programmable with a range of 1 ms to 65 seconds On or Off-delay of the output. Can also be used as a pulse stretcher.

Counter- style is easily programmed to count pulses or intervals and produce a reliable output ranging 0 to 65535.

Speed Monitor- programmable for over or underspeed rotation monitoring with a frequency range of 0.015 Hz to 1 kHz. After programming, the output is activated if speed changes by 5%.

Universal- programmable for all functions listed above. Programming notes: Single function models done via simple teach-in step using the control line. Universal model is configurable via a PDA, download software at www.softnoze.com

Specifications	Model Numbers				
Function	All-in-One	Timer	Counter	Inverter	Frequency
PNP (Sourcing)	PC-UP	PC-TP	PC-CP	PC-IP	PC-FP
NPN (Sinking)	PC-UN	PC-TN	PC-CN	PC-IN	PC-FN
Minimum Preset	Vary, see model specifications at right.	1ms	1	N/A	0.15 Hz
Maximum Preset		65,535	65,535	N/A	1,000 Hz
Operation Freq. (max)	8Khz	10Khz	10Khz	10Khz	1,000 Hz
Operational Features	On-delay timer, falling delay, wipe contact, counter, frequency control (overspeed monitor), inverter and converter. PDA programmable via software and IR port at distance of 10-50cm.	Programmable for rise, delay and fall, delay time.	Programmable pulse or interval counting.	Programmable conversion of sensor 's output, from N.O. to N.C. or from N.C. to N.O.).	Programmable frequency detection, generates output when frequency falls below approx. 5%.
Common Specifications	Rated operational voltage: 10...30Vdc Supply voltage: 12...24Vdc Input resistance: >10k Ohm Time-in delay: 100ms Load current capacity: 400mA Short circuit protection: Yes Ambient temperature range: 0..60°C(32..140°F)		Remote teach: Function indication: Environmental protection: Housing material: Input connection: Output connection:	Yes LED Red IP 67 PBTP/PA M12 4-pin Male M12 4-pin Female	

SoftNoze Is Sensor Integration

The world of Sensor Accessory Solutions

Consider all the steps involved in specifying and applying sensor. Then consider their costs to you, your company and or the end customer(s). You will find that the purchase price of a sensor is only a fraction of the total cost when compared to all the other installation-related costs:

Locating

Time required searching out the right bracket, guard or accessory,

or the Design Time

Accessory design and drafting time,

Fabrication

Fabrication and finishing processes,

Documentation

Maintaining documentation and information flow,

Inventory

Inventory costs for WIP and finished stock,

Installation

Installation time (easy vs. difficult),

Adjustment/Setup

Time required to achieve final adjustment and setup,

Downtime

Downtime lapses during start-up test and later during production, and finally

Changeout/Replacement

Hassles inherent to the removal, replacements and necessary readjustments.

SoftNoze's accessory solutions will help you effectively address all the above issues. Let our products add value to each step of your sensor implementation cycle. Each accessory is engineered for your sensing job. Look to SoftNoze to reduce your costs, in addition to improving the quality of your machine designs. Industrial Sensor Integration, it's our single focus at SoftNoze!



Proxtrol™ Limit Switches



Words about SoftNoze:

"Broad product offering, quick turn around on 'specials' and competitive pricing makes SoftNoze our first choice for sensor accessories!"

-Ed Seguin, Inside Sales Manager, H.H. Barnum Company

We feel an obligation to our customers to save them money whenever we can. By offering value-added engineering, coupled with unique SoftNoze products to our customers, we have saved our clients thousands of dollars each year."

-Mike Smith, Industrial Sales & Engineering Co.

Reed Business Information.

December 2001

Product Design

and Development

Excellence in Design - Engineering Award

Finalist

Sensor Mounting System™

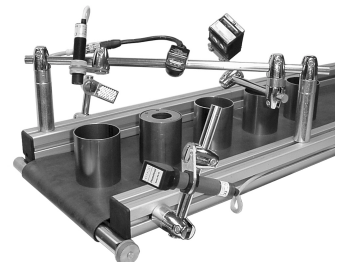

SoftNoze Is Sensor Integration

Monitoring your processes places sensors in harm's way

Lowest-level components can have big impacts on production

By Brett B. Truett,
SoftNoze USA, Inc.



By definition, proximity sensors are noncontact devices so, theoretically, they should last forever. However, a great deal of downtime is attributed to damaged sensor. What is going on here? How can sensor-related downtime be minimized or prevented altogether?

A recent visit to an automobile manufacturer revealed that the surprising culprit for the potential 350 plus hours of annual downtime was a single inductive proximity sensor. Another investigation at a robotic painting facility turned up another failing sensor, which caused downtime valued at \$300 per minute. In yet another application at Tier 2 automotive supplier, a welding fixture was destroying four proximity sensors every month, resulting in repeated instances of costly downtime, see **figure 1**.

How do situations like these happen, and are they isolated cases? This article reviews sensor failures and the expensive downtime that these breakdowns can cause. It also explores methods available for improving sensor performance and reducing a plant's downtime.

Figure 1. A welding fixture is modified by placing each sensors into a Quicktube™ mount. Use of Quicktubes prevent sensors from being damaged or destroyed due to impacts from parts.

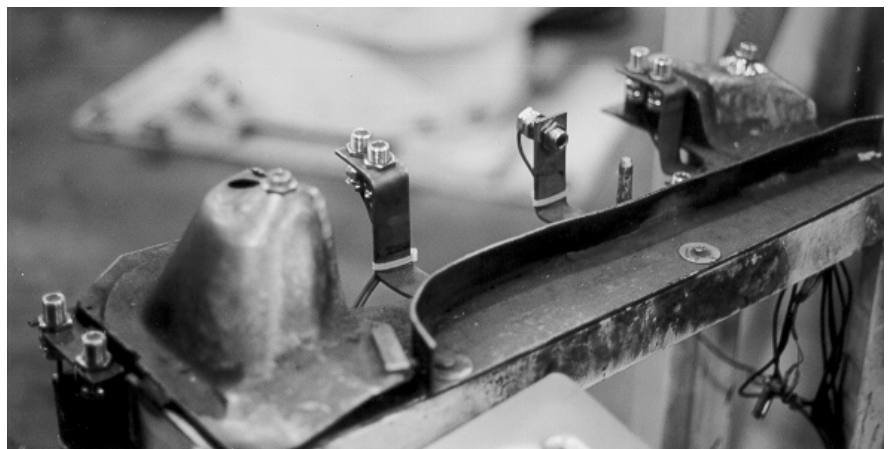

Monitoring processes... (continued)



Close to the Action

Figure 2 provides the average cost of downtime in various industries, although different stages of each manufacturing process obviously vary in cost. For example, if a less critical, offline process shuts down at an automotive plant, it may cost as little as \$100 per hour. However, if an accidental failure brings vehicle final assembly to a halt, expenses can run as high as \$15,000 per minute.

Engineers and technicians who are responsible for helping to reduce downtime and maintain smooth and efficient manufacturing processes perhaps should examine sensor applications for potential productivity improvements.

A common mistake is to allow obvious problems to continue until downtime occurs. For example, a sensor that must be adjusted continuously to achieve proper operation should serve as a sign that something is wrong with the application. Abnormal wear and tear that results in abrasion damage on the faces of proximity sensors provide another clue that something is wrong, **see Figure 3**.

Instead of ignoring such signs, engineers and technicians should take action before sensors are damaged fatally. They may find that failed sensors, rather than a control system's overall design, are responsible for most downtime. This is not surprising because sensors are the lowest-level components in automation systems and are merely millimeters - and often less - from the action.

Some plants have created special teams whose sole missions are to identify and eliminate potential equipment problems. At one such facility, each new piece of equipment's sensors and switches must pass the in-house team's close inspection before the machine can be used in production. The team often goes to great lengths and considerable expense to ensure that no sensors fail after the start button is pushed. The team members also take digital before-and-after photographs to document their work for their superiors.

Each sensor application is inspected to ensure that the sensors trigger reliably and have enough of a safety margin to accommodate slight process modifications, as well as normal wear and tear. Sensors that appear to perform marginally or that do not tolerate small changes either are upgraded or another technology is substituted. Brackets that hold sensors but may bend during production are replaced with heavy block-style mounts that cannot bend. A sensor body or face that is susceptible to wear from process debris is fitted with a housing or protective cap.

Should the team decide that other personnel should not be able to adjust a sensor's position, measures are implemented to render the sensor nonadjustable.

The market for noncontact proximity sensors continues to grow steadily. Often, proponents of these sensors suggest that the devices are immune to wear because they have no moving parts. However, the components and mechanisms that sensors monitor do wear, which contributes to damaging overtravel. Wear is a fact of life, and the proof is in the multibillion-dollar maintenance (MRO) market for replacement parts and repair.

Downtime Expense	
Industry*	Cost per hour
Food processing	\$500
Printing & packaging	\$600
Pulp & paper	\$1,000
Machining & CNC	\$5,000
Automotive	\$45,000

* Averages, varies depending on products stage in manufacturing process. For example in automotive, final assembly downtime is often much more costly than component production downtime.

Figure 2. Downtime expense can run \$45,000 per hour if vehicle final assembly is brought to a stop.

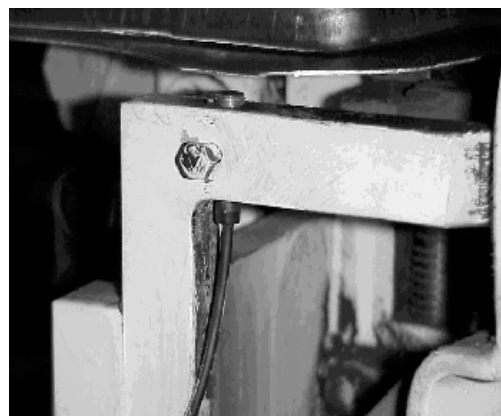

Figure 3. The sensor at left was repeatedly damaged until it was placed into a SoftNoze Banking Screw Adapter (right) that isolated it from damage.

Monitoring processes... (continued)

How Costs Mount

The cost of even a small amount of downtime can add up quickly. Even a company that experiences minimal downtime may be losing more than it realizes. It should consider all of the elements that comprise sensor replacement cost, including lost production and salaries paid to idled workers and those who find and repair the sensor and fix damaged equipment or products.

Here is where the costs add up from; 1) Identifying problem/sensor, 2) Securing a replacement device, time to identify brand and part number (and all the purchasing transactions; purchase orders, shipping and receiving), 3) Inventory expenses, 4) Retrieving a part from vendor or spare-parts bin, 5) Installing and setting up a new sensor, 6) Restarting and confirming operation and finally 7) Documenting the situation.

These potential expenses show how quickly downtime adds up for manufacturers. For example, one automotive manufacturer was replacing an average of one inductive proximity sensor per day on the third shift. The third-shift maintenance engineer was accustomed to such system “quirks” and was not concerned - until the plant engineer learned that both the first and second shifts were experiencing the same problem.

The problem was traced to a proximity sensor located in an engine block machining fixture. Although the engine blocks were not resting directly on the sensor, the sensor was damaged by the blocks. As they were loaded and unloaded, metal chips that had built up during machining were compressed into the sensing face. These damaged sensors caused an average of 30 minutes of downtime per incident, including time to identify fault sensors, assist the line operator, obtain and install replacement sensor, and test and readjust the devices.

Some quick math yielded amazing number, the total cost is equal to (0.5 hour x 3 shifts x 5 days x 49 weeks x \$45,000 per hour = 367.5 x \$45,000) \$16.5 million. What initially seemed like a case of a few nuisance calls was actually a severe and tremendously expensive problem. Installing a SoftNoze Cushioned Sensor Mount, which allowed the sensor to retract was the solution.

This plant was not alone in its costly education process. In a robotic painting facility, overspray resulted in sensors, as well as products, being painted, causing the sensors to shut down the process. Teflon covers that snapped over the sensors eliminated the paint buildup and restored reliable sensing. Also, at a Tier 2 automotive supplier stampings were hitting, wearing, and damaging sensors. Rather than continuing to destroy sensors, the company moved the sensors away from the action using Banking Screw Adapters. The damage was stopped immediately.

Experience and research have shown that many sensors are subjected routinely to hazards that damage them. These dangers transform typically “unlimited-lifetime” sensors into serious downtime culprits. Potential threats to sensors include:

- Unplanned environmental factors and or post production changes to equipment,
- Worn equipment,
- Personnel who make nonqualified adjustments,
- Unplanned increases in equipment cycle times that lead to increased loads and travel,
- Bent brackets that place sensors too close to moving parts,
- Inadequate guarding,
- Changes in the type of target material,
- Shock, vibration and shaft runout, and lastly
- Misapplication of sensors

Conclusion

Key engineering and technical personnel are expected to add value to a facility. Increasing plant efficiency often is a top priority. Because sensors play such a vital role in all automation processes, it makes good sense to know what problems can occur.



SoftNoze CPR Solutions







Simple or complex, a few pieces or thousands

SoftNoze has completed hundreds of Custom Product Requests. You'll be amazed just how easy it can be! Just copy, complete and submit the form on the next page (copy and FAX this form, or go to www.softnoze.com for our online version).

Take a few minutes to submit the CPR form and SoftNoze will work hard to deliver a valuable solution. After submitting your CPR form, you can move onto your main machine design tasks with confidence. SoftNoze will confirm your request and then handles the finer details of your sensor integration.

Although simplified in this diagram, each project is handled by our in-house CPR system, by a degreed mechanical engineer. We use a proven project management system, tracking each step, using the latest software. Molds, dies, CNC machining, traditional machine tools, rapid prototyping- SoftNoze has completed all types of projects for leading sensor manufactures, automotive suppliers and a wide variety of end users. Put us to work today!

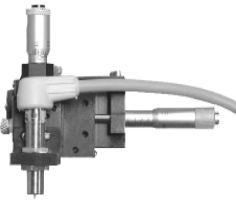

 <p>Brackets Here are a few of the many special brackets we supply our customers.</p>	 <p>Protective Hood Air Purge Hoods keep ambient light and debris from causing trouble for photoelectrics.</p>	 <p>Guards Often used to protect photoelectric sensors.</p>	
 <p>Cushioned Sensor Mounts An all plastic spring-loaded housing protects a sensor from damaging over-travel.</p>	 <p>Lock Outs These safety switches can comply with OSHA's lockout /tagout programs.</p>	 <p>Proxtrol™ Devices SoftNoze can make a standard prox control many machine functions.</p>	 <p>Solid Model in Design Phase</p>
 <p>ProxAntenna™ Protects tubular sensors from impact from any angle. Can be mounted in any orientation.</p>	 <p>Custom BSA's One of many modifications to our ultra-popular line of Banking Screw Adapters™.</p>	 <p>Precision Mounts Displacement probes and lasers can be precisely positioned and readjusted in 1, 2 or 3 planes.</p>	 <p>Actual Product</p> <p>Light Curtain Hinge Light curtain OEM required an adjustable and lockable hinge for aiming and securing their product.</p>

Custom Product Request (CPR)

Free yourself! SoftNoze will act as your Engineering, Prototyping, Production and Inventory Departments, shipping you just the bracket and accessory quantities you need, right when you want them. We are uniquely qualified with both the knowledge and ability to support you. Simply complete and submit this form and SoftNoze will assign a "CPR" number and promptly return a confirmation. We will handle everything else until a quotation and or a solution is in your hands. Put us to work today and free yourself to handle other tasks.

For SoftNoze use only	
CPR #	CSM #

A. Contact Information

Your Name _____ Title _____
Company _____ Address _____
City _____ State _____ Zip _____
Telephone _____ Fax _____ Email _____

B. Type of Business

End User OEM System Integrator Distributor Sensor Manufacturer/Marketer

C. Sensor or device type

Photoelectric Inductive Capacitive Ultra Sonic Limit Encoder Transducer Other

Brand _____ Part number _____

D. Application Description

 (explain your application and required features- attaching a sketch is very helpful)

E. Materials of Construction

F. Project Information

1) Target design proposal date: _____ 2) Desired quotation date: _____
3) Target implementation date: _____ 4) Are prototypes desired? Yes No Qty: _____
5) Are/will you supply SoftNoze with samples, parts or drawings? _____

G. Quoting Data

1) Quantity required: _____ 2) Is this a one time requirement? Yes No
3) If a reoccurring requirement, please estimate your annual usage? _____
4) Is a budget in place for this project? Yes No 5) Target price range, (optional): _____

CPR Notices

1) Often custom SoftNoze solutions are provided at no charge. However, depending on project scope and depth, nonrecurring engineering (NRE) may apply. NRE is charged only after you have agreed and supplied a Purchase Order. 2) Our response time will vary depending upon work load, but SoftNoze will always confirm your request within 24 hours. Rapid CPR Solutions can be rushed for crisis or emergency situations, please note this need in Section "F" above.

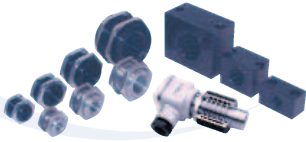

Cushioned Sensor Mounts



Proxtrol™ Devices



Metal Brackets



Sight Glass & Sensor Wells



Covers, Shields & Caps



Tubular Sensor Mounts



Photoelectric Accessories

Looking for a dependable source for sensor, switch and transducer mounting brackets and accessories? Then SoftNoze™ is the right partner for you!

While control manufacturers excel at providing the “sensing” technology you need, SoftNoze™ excels at providing mounting brackets and accessories to maximize your control’s capabilities.

From simple mounts like our RiteAngle™ Bracket, to patented solutions like spring-loaded mounts and our newest EMC Technology™, SoftNoze™ will keep your systems up and running.

What You Need, When You Need It

At SoftNoze, we recognize how important sensor applications are to automation projects and production schedules. That’s why we spend all our time and resources making sure you get what you need:

- Superior Customer Service
- Broad Product Offering
- Specialty and Customized Products
- Rigid Quality Inspection
- Large Inventory of Stock Items
- Fast and Accurate Delivery

Standard SoftNoze Solutions

We have the broadest line of brackets and accessories in the industry, all designed and developed with the help of control users like yourself. SoftNoze-designed accessories go the extra mile to:

- Provide Easy Installation & Maintenance
- Decrease Control Wear & Tear / Increased Reliability
- Help Reduce or Eliminate Downtime

Custom Solutions - SoftNoze “CPR”

Can’t find what you need? No problem, SoftNoze has a wealth of engineering and manufacturing experience to assist you when your application calls for something new or if modifications are required:

- Streamlined Process that Keeps You Informed
- Estimates & Formal Quotations
- Production Manufacturing
- Stocking Programs
- Solution Generation & Proposals
- Prototype Development & Delivery
- Private Labeling
- On-time Deliveries

Local Sales and Technical Support Provided By:

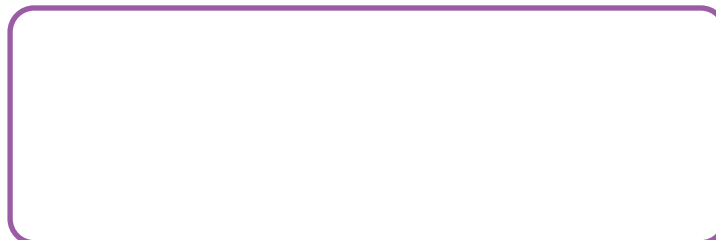

Publication No. 50253 Rev. 3

Think SoftNoze for: Inductive, Capacitive, Photoelectric, Ultrasonic, Safety & Limit Switch, Encoder and Transducer Mounts & Accessories.